



**Direct Line Insurance Group plc, U K Insurance Limited and
Churchill Insurance Company Limited**

**Single Solvency and Financial Condition Report
For the year ended 31 December 2017**

Contents

	Page		Page
Introduction	1	E. Capital management	53
Executive summary	2	E.1 Own funds	54
A. Business and performance	6	E.2 Solvency capital requirement and minimum capital requirement	58
A.1 Business	7	E.3 Use of the duration-based equity risk sub-module in the calculation of the solvency capital requirement	61
A.2 Underwriting performance	10	E.4 Use of the internal model	61
A.3 Investment performance	14	E.5 Non-compliance with the minimum capital requirement and non-compliance with the solvency capital requirement	64
A.4 Performance of other activities	16	E.6 Any other information	64
A.5 Any other information	17		
B. System of governance	18	F. Other information	65
Introduction: Assessment of the adequacy of the Group's system of governance	19	F.1 Approval by the Boards	66
B.1 General information on the system of governance	20	F.2 Report of the external independent Auditor	67
B.2 Fit and proper requirements	24	F.3 Forward-looking statements disclaimer	72
B.3 Risk management system, including the Own Risk and Solvency Assessment	25	F.4 Glossary	73
B.4 Internal control system	29	G. Quantitative Reporting Templates	75
B.5 Internal audit function	31	G.1 Summary of Quantitative Reporting Templates	76
B.6 Actuarial function	31	G.2 Direct Line Insurance Group plc	77
B.7 Outsourcing	32	G.3 U K Insurance Limited	92
B.8 Any other information	33	G.4 Churchill Insurance Company Limited	111
C. Risk profile	34		
Introduction : Prudent person principle	35		
C.1 Underwriting risk	35		
C.2 Market risk	37		
C.3 Credit risk	39		
C.4 Liquidity risk	40		
C.5 Operational risk	41		
C.6 Other material risks	41		
C.7 Any other information	41		
D. Valuation for solvency purposes	42		
D.1 Assets	43		
D.2 Technical provisions	47		
D.3 Other liabilities	50		
D.4 Alternative methods of valuation	51		
D.5 Any other information	52		

Introduction

Direct Line Insurance Group plc (the “**Company**”) together with its subsidiaries (the “**Group**”) has prepared a Single Solvency and Financial Condition Report (“**SFCR**”) as at 31 December 2017, in accordance with permission granted by the Prudential Regulation Authority (“**PRA**”) in December 2015 to produce a Single SFCR. This permission allows the Group to produce one SFCR that covers both the Group and its individual regulated subsidiaries and is valid until 31 December 2020.

The Group’s regulated entities are U K Insurance Limited (“**UKI**”) and Churchill Insurance Company Limited (“**CIC**”). In meeting the requirements for a Single SFCR, information is reported for the Group, UKI and CIC separately except where that information is equivalent in both nature and scope at Group level to that at regulated subsidiary level. The boards of Directors of the Company, UKI and CIC (the “**Boards**”) have the same membership. Much of the information in the SFCR is equally relevant to the Group, UKI and CIC. Where this is not the case, this has been highlighted.

The requirement to produce an SFCR follows the introduction of Solvency II as the new solvency framework which was implemented on 1 January 2016 as the capital adequacy regime for the European insurance industry. Solvency II has established a set of EU-wide capital requirements and risk management standards with the aim of increasing protection for policyholders.

The SFCR presents information on the business and performance, system of governance, risk profile, valuation for solvency purposes and capital management of the Group, UKI and CIC. Relevant information about the business of the Group is also included in the Group’s Annual Report & Accounts which is the primary vehicle for reporting performance, consolidated financial statements, corporate governance and risk management to the Group’s investors. The Group’s Annual Report & Accounts 2017 was published on its website in March 2018 and a copy can be found at: www.directlinegroup.com/investors

Some elements of this report are subject to external audit as detailed in the Auditor’s report, which can be found on page 67.

Executive summary

Section A – Business and performance summary

The Group

Direct Line Insurance Group plc's mission is to make insurance much easier and better value for customers. We have shown ourselves to be a business that can deliver great things for our customers through our brands and at the same time deliver returns for our shareholders. The Group has multiple brands, products and distribution channels. Each enables customers to choose the appropriate cover to protect their cars, homes, holidays, businesses and pets.

The Group delivered a strong performance in 2017, reflecting its success in satisfying customers and focussing on profitability and returns. There was strong growth in direct own-brands premiums and in-force policies as customers responded positively to the many improvements made in the business.

Brands

Direct Line has maintained its brand heritage of speed, simplicity and a common sense human touch. Products are sold by phone and online. Churchill is one of Britain's most recognisable brands and markets products by phone and online, including price comparison websites ("PCWs"). Green Flag is a roadside rescue and recovery provider, which is sold as a standalone service and an additional optional product alongside motor insurance across all of the Group's brands. Privilege targets customers who mainly buy through PCWs. Direct Line for Business is an extension of the Direct Line brand that markets a range of business insurance products over the phone and online. NIG is our commercial insurance brand dedicated to the broker market and is focused on a number of specialisms including small and medium size enterprises ("SMEs"), agriculture and real estate. Brand Partners is the Group's partnerships arm, specialising in providing personal lines insurance and roadside rescue and recovery products to some well-known brands.

Lines of business

Motor

The Group is Britain's leading personal motor insurer measured by in-force policies¹, mainly represented through its well-known brands Direct Line, Churchill and Privilege, and also through partners. The Group insures approximately one in six insured cars on the road in the UK, representing 4.0 million in-force policies.

Home

The Group is one of Britain's leading personal home insurers measured by in-force policies¹. The Group reaches its customers by selling home insurance products through its own brands, Direct Line, Churchill and Privilege, and its partners – RBS, NatWest and Prudential.

Rescue and other personal lines

The Group is one of the leading providers of rescue and other personal lines insurance in the UK with 7.7 million in-force policies^{2,3}. This includes providing roadside assistance and recovery for customers through Green Flag, the UK's third-largest roadside recovery provider². The Group also offers customers protection for their holidays and pets and is the second-largest travel and the fourth-largest pet insurer respectively.

Commercial

The Group protects commercial businesses through its brands NIG, Direct Line for Business and Churchill, and through its partners RBS and NatWest. NIG sells its products exclusively through brokers operating across the UK. Direct Line for Business provides business, van and landlord insurance products direct to customers. Churchill sells business, landlord and van products direct to customers and through PCWs.

Solvency II lines of business

The policies underwritten by the Group are spread across the Solvency II lines of business including motor vehicle liability insurance, other motor insurance, fire and other damage to property insurance, general liability insurance, income protection insurance, legal expenses insurance, assistance and miscellaneous financial loss.

Business performance in 2017

On an International Financial Reporting Standards ("IFRS") basis in 2017, underwriting profit from Ongoing operations for the Group was £256.9 million. The underwriting result (for both current and prior year), instalment and other operating income and investment income were all higher than 2016. The underwriting performance was £308.9 million, a substantial increase over 2016 due to the non-repeat of the Ogden discount rate change impacting 2016 profit before tax by £217.3 million. In addition, 2017 benefitted from its reinsurance programme which was fixed prior to the Ogden discount rate change and strong growth and improved margins in the Motor business. Group profit before tax was £539.0 million reflecting a strong run-off result and a one-off charge related to the refinancing of debt in December 2017.

Notes:

1. Includes Direct Line, Churchill, Privilege and partner brands: RBS, NatWest, Prudential and Sainsbury's © GfK Financial Research Survey (FRS) six months ending January 2018, 14,063 adults interviewed for motor insurance and 12,214 for home insurance.
2. Mintel Vehicle Recovery – UK, September 2017.
3. Mintel Pet Insurance – UK, August 2017 and Mintel Travel Insurance – UK, February 2017

Executive summary continued

Section A of the SFCR has more information on the Group's business and performance in 2017 – see pages 6 to 17 of this report.

Section B – System of governance summary

The Company's board of Directors (the "Board") has overall oversight of the management of the Group. A major focus of the Board continues to be maintaining high standards of corporate governance, which the Board seeks to achieve through the Group's governance arrangements. The Board is committed to the principles of the UK Corporate Governance Code 2016 issued by the Financial Reporting Council (the "Code") and has complied with all of the principles of the Code throughout the financial year. The Board seeks to secure the long-term success of the Group and aims to deliver this by creating an open culture that encourages the Group to make decisions that are best for its shareholders and stakeholders.

The Boards have resolved to approve and adopt a High Level Control and System of Governance Framework document as a statement of the governance structure and requirements applicable to each company and the Group.

The Board has established a risk management model that separates the Group's risk management responsibilities into Three Lines of Defence as follows:

- the First Line of Defence is management who are responsible for owning and managing risks to achieve the Group's business objectives on a day-to-day basis;
- the Second Line of Defence is the Risk function which is responsible for the design and implementation of the Group's Enterprise Risk Management Strategy and Framework ("ERMF"), and the provision of proportionate oversight of and challenge to the business' management of risks, events and management actions; and
- the Third Line of Defence is Group Audit, which is responsible and accountable for providing an independent and objective view of the adequacy and effectiveness of the Group's risk management, governance and internal control framework.

Section B of the SFCR has more information on the Group's system of governance – see pages 18 to 33 of this report.

Section C – Risk profile summary

The following chart shows the UKI Solvency Capital Requirement ("SCR") of £1,361 million as at 31 December 2017, calculated using the approved internal model, by risk type. The SCR for the Group as at 31 December 2017 using its approved model was £1,393 million.

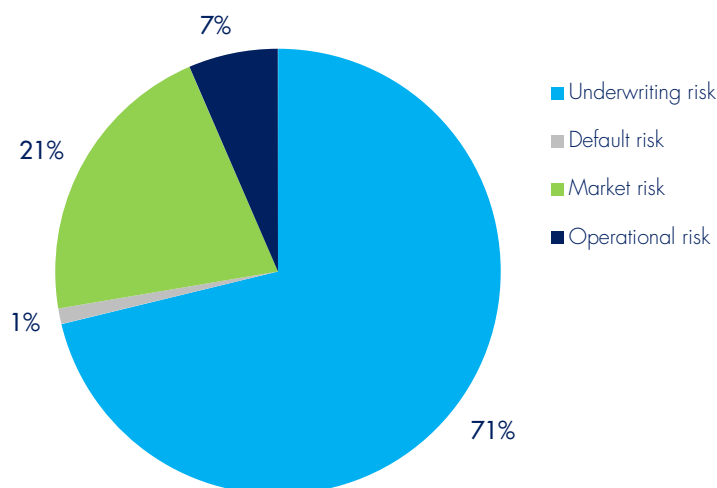

The risk profile of the Group has not changed materially over the reporting period.

Executive summary continued

Underwriting risk is the risk that future claims experience on business written is materially different from the results expected, resulting in current year losses. Underwriting risk includes reserve risk, catastrophe risk, the risk of loss or of adverse change in the value of the insurance liabilities resulting from significant uncertainty of pricing, underwriting and provisioning assumptions.

Market risk is the risk of loss resulting from fluctuations in the level and in the volatility of market prices of assets, liabilities and financial instruments.

Operational risk is the risk of loss due to inadequate or failed internal processes, systems, human error or from external events.

Credit risk is the risk of loss resulting from default on cash inflows and / or changes in market value of issuers of securities, counterparties and any debtors to which the Group is exposed.

Section C of the SFCR has more information on the Group's risk profile – see pages 34 to 41 of this report.

Section D – Valuation for solvency purposes summary

In accordance with the Solvency II requirements, the Group values all assets and liabilities on the balance sheets of the Group and its regulated entities at fair value, which represents an amount for which they could be exchanged between knowledgeable willing parties in an arm's length transaction. Goodwill and intangible assets are valued at zero.

An analysis of the Solvency II material classes of assets and liabilities is provided in sections D.1 and D.3 respectively. Section D details the recognition and valuations bases, the judgements and any assumptions made, including sources of estimation uncertainty applied for Solvency II, and compares these with judgements and assumptions made in the preparation of IFRS financial statements.

Section D.2 describes the bases, methods and assumptions for the valuation of Solvency II technical provisions, including the estimation uncertainty, and compares these with the bases, methods and assumptions used in the preparation of the IFRS financial statements.

A summary of the Solvency II balance sheets for the Group and its regulated subsidiaries is set out below:

As at 31 December 2017	Group £m	UKI £m	CIC £m
Total investments	6,551.9	6,326.1	17.7
Property, plant and equipment held for own use	58.7	–	–
Reinsurance recoverables	1,136.1	1,120.2	28.8
Insurance and other receivables	243.0	168.0	1.0
Cash and cash equivalents	258.0	245.1	–
Deferred tax assets	41.9	–	–
Other assets	73.5	–	–
Total assets	8,363.1	7,859.4	47.5
Technical provisions	5,205.8	5,185.1	33.5
Provisions other than technical provisions	74.2	31.7	–
Deferred tax liabilities	–	13.2	0.1
Derivatives	12.0	12.0	–
Debts owed to credit institutions	54.1	48.6	–
Insurance and other payables	289.7	307.5	0.6
Subordinated liabilities	264.8	529.6	–
Total liabilities	5,900.6	6,127.7	34.2
Excess of assets over liabilities	2,462.5	1,731.7	13.3

Section D of the SFCR has more information on the Group's valuation for solvency purposes – see pages 42 to 52 of this report.

Executive summary continued

Section E – Capital management summary

In June 2016, UKI, the Group's principal underwriter, received approval from the PRA to use its Internal Economic Capital Model ("IECM") which forms part of a Group-wide Partial Internal Model ("PIM") which has been in use from the same date.

The Group aims to manage its capital efficiently and generate long-term sustainable value for shareholders, while balancing operational, regulatory, rating agency and policyholder requirements. The policies and processes that the Group adopts to manage its own funds to mitigate the risk of breaching regulatory and internal capital adequacy are described in the Group's Capital Management Minimum Standard.

The SCR coverage ratio was as follows for the Group and regulated entities:

As at 31 December 2017	Group £m	UKI £m	CIC £m
Solvency capital requirement	1,392.7	1,361.5	1.7
Capital surplus above solvency capital requirement	906.0	599.8	11.6
Capital coverage ratio (%)	165%	144%	771%

Section E of the SFCR has more information on the Group's capital management – see pages 53 to 64 of this report.

Reconciliation of excess of assets over liabilities to own funds

As at 31 December 2017	Group £m	UKI £m	CIC £m
Excess of assets over liabilities	2,462.5	1,731.7	13.3
Foreseeable dividends	(390.7)	(300.0)	–
Own shares ¹	(38.0)	–	–
Less deferred tax assets	(41.9)	–	–
Excess of assets over liabilities (Tier 1)	1,991.9	1,431.7	13.3
Subordinated liabilities (Tier 2)	264.8	529.6	–
Deferred tax assets (Tier 3)	41.9	–	–
Own funds	2,298.6	1,961.3	13.3

Note:

1. Own shares (held directly) for employee share trusts form part of Tier 1 own funds and are included within assets on the Solvency II balance sheet.

Material changes

There have been no material changes to the business and performance, system of governance, risk profile, valuation for solvency purposes or capital management over the reporting period.

Section A: **Business and performance** (unaudited)

In this section:

- A.1 Business
- A.2 Underwriting performance
- A.3 Investment performance
- A.4 Performance of other activities
- A.5 Any other information

A. Business and performance

A.1 Business

Name and legal form

Direct Line Insurance Group plc is a public limited company incorporated in England and Wales. It has a premium listing on the UK Listing Authority's Official List. The Company's Ordinary Shares (EPIC:DLG) are admitted to trading on the London Stock Exchange.

Supervision

The Company's supervisory authority responsible for financial supervision is:

Prudential Regulation Authority (PRA)
Bank of England
20 Moorgate
London
EC2R 6DA
Switchboard: +44 (0)20 7601 4444
Email: PRA.FirmEnquiries@bankofengland.co.uk

Auditor

External Auditor:
Deloitte LLP
Hill House
1 Little New Street
London
EC4A 3TR
Phone: +44 (0)20 7936 3000

Holdings of qualifying holdings

There were no holders of qualifying holdings in the Company as at 31 December 2017. A 'qualifying holding' is a direct or indirect holding in the Company which represents 10% or more of the capital or of the voting rights or which makes it possible to exercise a significant influence over the management of the Company.

Group ownership and structure

The Company is the ultimate holding company of the Group. The underwriting subsidiaries of the Company, both of which are 100% owned, are as follows:

- U K Insurance Limited – general insurance
- Churchill Insurance Company Limited – general insurance

The Group publishes a Single SFCR following PRA approval and a modification to the PRA Handbook. This is a single publication of a Group SFCR for Direct Line Insurance Group plc and its subsidiaries, and solo SFCR reports for both UKI and CIC. Information is separately identifiable by reference to the Group, UKI and CIC.

Basis of consolidation

The Solvency II Group balance sheet is a full consolidation in accordance with Article 335 and there are no differences in the scope of the Group used for the Group's consolidated financial statements in its Annual Report & Accounts 2017.

A. Business and performance continued

Subsidiaries

The subsidiary undertakings of the Company are set out below. Their capital consists of Ordinary Shares which are unlisted. In all cases, the Company owns 100% of the Ordinary Shares, either directly or through its ownership of other subsidiaries, and exercises full control over their decision making.

Name of subsidiary	Place of incorporation and operation	Principal activity
Directly held by the Company:		
Direct Line Group Limited ¹	United Kingdom	Intermediate holding company
DL Insurance Services Limited ¹	United Kingdom	Management services
Finsure Premium Finance Limited ¹	United Kingdom	Non-trading company
Inter Group Insurance Services Limited ¹	United Kingdom	Non-trading company
UK Assistance Accident Repair Centres Limited ¹	United Kingdom	Motor vehicle repair services
UK Assistance Limited ¹	United Kingdom	Dormant
U K Insurance Business Solutions Limited ¹	United Kingdom	Insurance intermediary services
U K Insurance Limited ^{2,3}	United Kingdom	General insurance
Indirectly held by the Company:		
10-15 Livery Street, Birmingham UK Limited ⁴	Jersey	Non-trading company
Churchill Insurance Company Limited ¹	United Kingdom	General insurance
Direct Line Insurance Limited ¹	United Kingdom	Dormant
DLG Legal Services Limited ⁵	United Kingdom	Legal services
DLG Pension Trustee Limited ¹	United Kingdom	Dormant
DL Support Services India Private Limited ⁶	India	Support and operational services
Farmweb Limited ¹	United Kingdom	Non-trading company
Green Flag Group Limited ²	United Kingdom	Intermediate holding company
Green Flag Holdings Limited ¹	United Kingdom	Intermediate holding company
Green Flag Limited ²	United Kingdom	Breakdown recovery services
Intergroup Assistance Services Limited ¹	United Kingdom	Non-trading company
National Breakdown Recovery Club Limited ¹	United Kingdom	Dormant
Nationwide Breakdown Recovery Services Limited ¹	United Kingdom	Dormant
The National Insurance and Guarantee Corporation Limited ¹	United Kingdom	Dormant
UKI Life Assurance Services Limited ¹	United Kingdom	Dormant

Notes:

1. Registered office at: Churchill Court, Westmoreland Road, Bromley, BR1 1DP.
2. Registered office at: The Wharf, Neville Street, Leeds, LS1 4AZ.
3. U K Insurance Limited has a branch, as defined in section 1046 (3) of the Companies Act 2006, in the Republic of South Africa.
4. Registered office at: 22 Grenville Street, St Helier, JE4 8PX, Jersey.
5. Registered office at: 42 The Headrow, Leeds, LS1 8HZ.
6. Registered office at: 4 Aradhana Enclave, Sector 13, Rama Krishna Puram, New Delhi, South West Delhi, Delhi, 110066, India.

A. Business and performance continued

Group structure

Direct Line Group Legal Entity Structure as at 31 December 2017
All Current Legal Entities

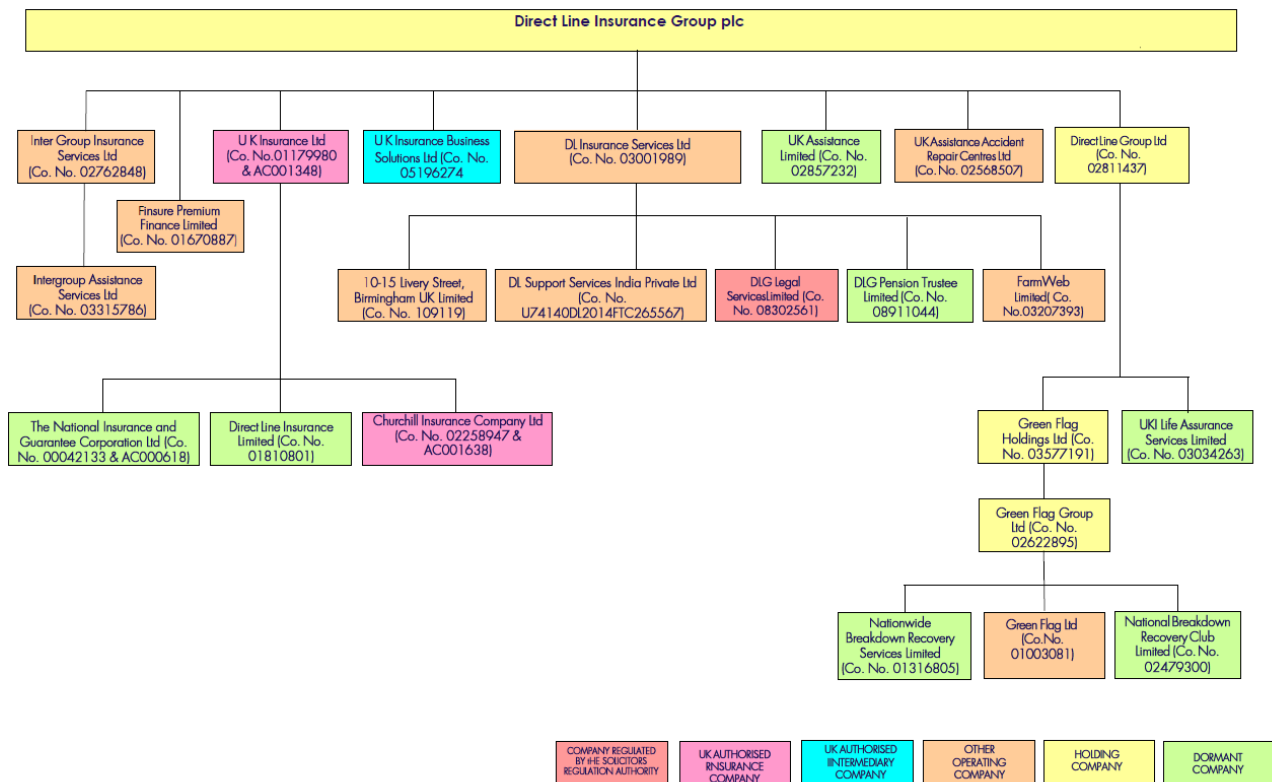

Lines of business

The Group provides personal lines, motor and home insurance products and is mainly represented through its highly recognised brands Direct Line, Churchill and Privilege, and also through its partners. The Group insures around one in six cars on the road in the UK, representing 4.0 million in-force policies, and is Britain's leading personal home insurer measured by in-force policies. The Group provides roadside assistance and recovery for customers through its Green Flag roadside recovery provider. The Group also offers customers protection for their pets and holidays.

The Group protects SMEs through its brands NIG, Direct Line for Business and Churchill, and through its partners RBS and NatWest. NIG sells its products exclusively through brokers operating across the UK Direct Line for Business provides business, van and landlord insurance products direct to customers. Churchill sells business, landlord and van products direct to customers and through PCWVs.

Motor vehicle liability insurance

The Group's personal and commercial lines motor vehicle liability insurance products provide cover against third-party property damage and bodily injury liability cover.

Other motor insurance

The Group's personal and commercial lines other motor insurance products provide cover against accidental damage, fire, theft and windscreen damage.

Fire and other damage to property insurance

The Group's personal and commercial lines insurance products provide cover against accidental damage, escape of water, fire, subsidence, theft and weather (including storms and flooding).

General liability insurance

The Group's commercial lines general liability insurance products provide cover against personal accident, employers' liability, public liability for injury, public liability to property and disease.

Income protection insurance

The Group's creditor income protection insurance product includes cover in the event of being unable to continue working.

A. Business and performance continued

Legal expenses insurance

The Group offers legal expenses insurance cover that includes motor legal protection and family legal protection, including for employment disputes and personal injury. The cost of settling a claim made by a non-fault policyholder under a motor legal protection policy will be incurred by the third-party insurer. However, if a claim is made by a third party against an at-fault Group policyholder, the cost to the Group will be included in motor liability or other motor insurance claims and not in legal expenses claims.

Assistance

The Group's personal lines assistance products cover motor rescue, car hire and travel (including cancellation, medical and non-medical expenses).

Miscellaneous financial loss

The Group's personal and commercial lines miscellaneous financial loss products include creditor protection for unemployment, pet, including veterinary fees, home response and emergency, pecuniary loss for business interruption and commercial special risks.

Annuities stemming from non-life insurance contracts and relating to insurance obligations other than health insurance obligations

The Group's personal and commercial lines insurance products provide cover for motor vehicle liability insurance and general liability insurance that are settled by Periodic Payment Order ("PPO") as awarded by a court under the Court Act 2003. As the Group has no non-life insurance contracts relating to health insurance obligations, future references within this document to 'Annuities from non-life' refer only to non-life annuities not relating to health insurance.

Geographical areas

The Group carries out its business primarily in the United Kingdom; a small number of policies are sold in the Republic of Ireland.

Significant business or other events

There are no significant business or other events to report in respect of the year ended 31 December 2017.

A.2 Underwriting performance

The allocation of IFRS premiums, claims and expenses to Solvency II lines of business is an allocation that is performed for the purpose of producing Quantitative Reporting Templates ("QRTs") and the SFCR and is based on simplified allocations. The Group does not report its IFRS performance internally by Solvency II lines of business. The Board manages the Group primarily by product type and presents a segmental analysis in the Group's Annual Report & Accounts 2017 on page 139, on that basis. The segments, which are all UK based, reflect the management structure whereby a member of the Executive Committee is accountable to the Chief Executive Officer ("CEO") for each of the operating segments. For an understanding of the Group's IFRS performance, consistent with how the Group is managed, the Operating review starting on page 30, the Finance review starting on page 34 and the Financial statements starting on page 104 provide more relevant information.

Group – by line of business

For the year ended 31 December 2017	Motor vehicle liability insurance £m	Other motor insurance £m	Fire and other damage to property insurance £m	General liability insurance £m	Income protection insurance £m	Legal expenses insurance £m	Assistance £m	Misc. financial loss £m	Annuities from non-life £m	Total £m
Gross written premium	1,381.3	391.6	1,000.0	94.2	11.4	86.7	312.4	114.5	–	3,392.1
Gross earned premium	1,320.2	374.3	1,026.3	93.3	11.4	87.3	312.4	114.5	–	3,339.7
Reinsurers' share	(145.3)	–	(56.6)	(0.9)	–	–	(0.6)	(1.3)	–	(204.7)
Net earned premium	1,174.9	374.3	969.7	92.4	11.4	87.3	311.8	113.2	–	3,135.0
Gross claims	(512.3)	(121.0)	(443.8)	(20.8)	(4.0)	(12.0)	(172.1)	(67.5)	(42.8)	(1,396.3)
Reinsurers' share	(176.0)	–	(8.0)	(21.5)	–	0.2	0.6	(2.5)	24.1	(183.1)
Net claims	(688.3)	(121.0)	(451.8)	(42.3)	(4.0)	(11.8)	(171.5)	(70.0)	(18.7)	(1,579.4)
Expenses incurred	(443.2)	(135.3)	(451.3)	(41.5)	(7.8)	(15.4)	(105.5)	(32.2)	(2.6)	(1,234.8)
Underwriting profit before other expenses	43.4	118.0	66.6	8.6	(0.4)	60.1	34.8	11.0	(21.3)	320.8
Other expenses ¹										(11.9)
Underwriting profit										308.9

Note:

1. Other expenses relate to restructuring. A detailed breakdown is provided in the Group's Annual Report & Accounts 2017 within note 10: 'Operating expenses' on pages 142 and 143, a copy of which can be found at www.directlinegroup.co.uk

A. Business and performance continued

Group – by line of business

For the year ended 31 December 2016	Motor vehicle liability insurance £m	Other motor insurance £m	Fire and other damage to property insurance £m	General liability insurance £m	Income protection insurance £m	Legal expenses insurance £m	Assistance £m	Misc. financial loss £m	Annuities from nonlife £m	Total £m
Gross written premium	1,262.2	357.8	1,053.0	92.9	13.0	87.5	294.8	112.9	–	3,274.1
Gross earned premium	1,194.2	338.5	1,069.4	92.3	13.2	88.2	293.1	113.9	–	3,202.8
Reinsurers' share	(135.9)	–	(59.1)	(5.7)	–	–	(0.7)	(0.8)	–	(202.2)
Net earned premium	1,058.3	338.5	1,010.3	86.6	13.2	88.2	292.4	113.1	–	3,000.6
Gross claims	(1,140.5)	(133.6)	(391.1)	(80.7)	0.3	(6.5)	(152.5)	(68.3)	(40.4)	(2,013.3)
Reinsurers' share	341.5	–	(0.2)	23.7	–	–	0.1	(0.4)	10.5	375.2
Net claims	(799.0)	(133.6)	(391.3)	(57.0)	0.3	(6.5)	(152.4)	(68.7)	(29.9)	(1,638.1)
Expenses incurred	(400.1)	(124.9)	(505.0)	(39.4)	(13.3)	(15.2)	(97.4)	(35.8)	(3.0)	(1,234.1)
Underwriting profit before other expenses	(140.8)	80.0	114.0	(9.8)	0.2	66.5	42.6	8.6	(32.9)	128.4
Other expenses ¹										(39.9)
Underwriting profit										88.5

Note:

1. Other expenses relate to restructuring. A detailed breakdown is provided in the Group's Annual Report & Accounts 2017 within note 10: 'Operating expenses' on pages 142 and 143, a copy of which can be found at www.directlinegroup.co.uk

The table below reconciles underwriting profit for the Group to underwriting profit from Ongoing operations as reported in the Group's Annual Report & Accounts 2017.

For the year ended 31 December	2017 £m	2016 £m
Underwriting profit	308.9	88.5
Non-technical expenses	(20.8)	(35.1)
Run-off	(43.1)	(23.2)
Restructuring costs	11.9	39.9
Underwriting profit – Ongoing operations	256.9	70.1

The table below reconciles underwriting profit to profit before tax.

For the year ended 31 December	2017 £m	2016 £m
Underwriting profit	308.9	88.5
Non-technical expenses	(20.8)	(35.1)
Investment return	175.4	171.5
Instalment and other income	179.3	165.3
Operating profit	642.8	390.2
Finance costs	(103.8)	(37.2)
Profit before tax	539.0	353.0

Direct Line Insurance Group plc is the ultimate holding company for a vertically integrated general insurance group which has outsourced to companies within the Group the delivery of certain services and claims activities, for example the repair of motor vehicles. The cost of claims in UKI represents the full cost of claims, whereas in the consolidated Group, claims represents the cost less margin generated from such outsourced activities.

A. Business and performance continued

UKI

For the year ended 31 December 2017	Motor vehicle liability insurance £m	Other motor insurance £m	Fire and other damage to property insurance £m	General liability insurance £m	Income protection insurance £m	Legal expenses insurance £m	Assistance £m	Misc. financial loss £m	Annuities from nonlife £m	Total £m
Gross written premium	1,381.3	391.6	1,000.0	94.2	11.4	86.7	312.4	114.5	–	3,392.1
Gross earned premium	1,320.2	374.3	1,026.3	93.3	11.4	87.3	312.4	114.5	–	3,339.7
Reinsurers' share	(145.3)	–	(56.6)	(0.9)	–	–	(0.6)	(1.3)	–	(204.7)
Net earned premium	1,174.9	374.3	969.7	92.4	11.4	87.3	311.8	113.2	–	3,135.0
Gross claims	(522.3)	(203.0)	(443.8)	(20.9)	(4.0)	(12.0)	(172.1)	(67.4)	(41.7)	(1,487.2)
Reinsurers' share	(167.3)	–	(8.0)	(21.5)	–	0.2	0.6	(2.6)	23.1	(175.5)
Net claims	(689.6)	(203.0)	(451.8)	(42.4)	(4.0)	(11.8)	(171.5)	(70.0)	(18.6)	(1,662.7)
Expenses incurred	(443.5)	(138.3)	(454.1)	(41.6)	(7.8)	(15.5)	(104.7)	(32.2)	(2.8)	(1,240.5)
Underwriting profit before other expenses	41.8	33.0	63.8	8.4	(0.4)	60.0	35.6	11.0	(21.4)	231.8
Other expenses ¹										(11.9)
Underwriting profit										219.9

UKI

For the year ended 31 December 2016	Motor vehicle liability insurance £m	Other motor insurance £m	Fire and other damage to property insurance £m	General liability insurance £m	Income protection insurance £m	Legal expenses insurance £m	Assistance £m	Misc. financial loss £m	Annuities from nonlife £m	Total £m
Gross written premium	1,262.2	357.8	1,053.0	92.9	13.0	87.5	294.8	112.9	–	3,274.1
Gross earned premium	1,194.2	338.5	1,069.4	92.3	13.2	88.2	293.1	113.9	–	3,202.8
Reinsurers' share	(135.9)	–	(59.1)	(5.7)	–	–	(0.7)	(0.8)	–	(202.2)
Net earned premium	1,058.3	338.5	1,010.3	86.6	13.2	88.2	292.4	113.1	–	3,000.6
Gross claims	(1,155.8)	(171.5)	(391.1)	(80.7)	0.3	(7.8)	(152.5)	(68.3)	(41.1)	(2,068.5)
Reinsurers' share	340.9	–	(0.2)	23.7	–	–	0.1	(0.5)	10.5	374.5
Net claims	(814.9)	(171.5)	(391.3)	(57.0)	0.3	(7.8)	(152.4)	(68.8)	(30.6)	(1,694.0)
Expenses incurred	(402.9)	(126.1)	(506.9)	(39.4)	(13.3)	(15.1)	(96.0)	(35.6)	(3.0)	(1,238.3)
Underwriting profit before other expenses	(159.5)	40.9	112.1	(9.8)	0.2	65.3	44.0	8.7	(33.6)	68.3
Other expenses ¹										(39.7)
Underwriting profit										28.6

Note:

1. Other expenses relate to restructuring costs.

CIC

For the year ended 31 December	2017			2016		
	Motor vehicle liability insurance £m	Annuities from nonlife £m	Total £m	Motor vehicle liability insurance £m	Annuities from nonlife £m	Total £m
Gross written premium	–	–	–	–	–	–
Gross earned premium	–	–	–	–	–	–
Reinsurers' share	–	–	–	–	–	–
Net earned premium	–	–	–	–	–	–
Gross claims	7.3	(1.1)	6.2	(0.3)	(0.4)	(0.7)
Reinsurers' share	(5.9)	1.0	(4.9)	(2.3)	0.5	(1.8)
Net claims	1.4	(0.1)	1.3	(2.6)	0.1	(2.5)
Expenses incurred	0.1	0.2	0.3	(0.1)	(0.1)	(0.2)
Underwriting profit / (loss)	1.5	0.1	1.6	(2.7)	–	(2.7)

A. Business and performance continued

Underwriting performance – Group

The underwriting profit relates almost entirely to UKI which is the main underwriting company within the Group. CIC has ten historic claims reported in the undertaking.

At a Group level, profit from underwriting performance was £308.9 million, a substantial increase over 2016 due to the non-repeat of the Ogden discount rate change impacting 2016 profit before tax by £217.3 million. In addition, 2017 benefitted from its reinsurance programme which was fixed prior to the Ogden discount rate change and strong growth and improved margins in the Motor business.

The Group expenses incurred includes an intangible assets impairment of £56.9 million (2016: £39.3 million). The impairment is in respect of intangible assets capitalised on the balance sheet and primarily relates to IT projects which aim to improve customer experience, support growth and increase the efficiency of the business.

Analysis by line of business

Motor vehicle liability insurance

Gross written premium for motor vehicle liability insurance increased during 2017 as a result of in-force policy growth in combination with higher average premiums within Personal Lines.

The underwriting profit before other expenses of £43.4 million was a substantial improvement on 2016, which was impacted by the change of the Ogden discount rate to minus 0.75%.

Other motor insurance

Gross written premium for other motor insurance grew during 2017 with in-force policies growing along with an increase in rates.

The underwriting profit before other expenses of £118.0 million was an increase compared to 2016 following favourable claims experience and own brands in-force policy growth.

Fire and other damage to property insurance

Gross written premium for fire and other damage to property insurance was lower in 2017, driven by a decline in partnerships business, partially offset by increases in own brands performance.

The underwriting profit before other expenses of £66.6 million has declined from 2016, primarily as a result of claims inflation associated with escape of water alongside favourable prior years' claims development in 2016.

General liability insurance

Gross written premium for general liability insurance was a similar level compared to 2016.

The underwriting profit before other expenses of £8.6 million was substantially higher than the previous year, mainly due to a reduction of £9.7 million in 2016 as a result of the change in the Ogden discount rate and improved claims experience on prior years.

Legal expenses insurance

The cost of settling a claim made by a non-fault policyholder under a motor legal protection policy will be incurred by the third-party insurer. However, if a claim is made by a third-party policyholder under their motor legal protection policy against an at-fault Group policyholder, the cost will be included in motor vehicle liability insurance claims or other motor insurance claims.

Gross written premium for legal expenses insurance was broadly stable during 2017 and the underwriting profit before other expenses of £60.1 million was slightly lower than 2016.

Assistance

Gross written premium for assistance increased during 2017, primarily due to price increases in travel along with higher Green Flag sales.

The underwriting profit before other expenses of £34.8 million was lower compared to 2016, driven by adverse claims experience on travel.

Miscellaneous financial loss

Gross written premium for miscellaneous financial loss was a similar level compared to 2016.

The underwriting profit before other expenses of £11.0 million was higher than 2016; slightly adverse claims experience being more than offset by lower expenses.

Annuities from non-life insurance contracts, other than health obligations

The underwriting loss before other expenses improved compared to 2016 partially due to higher reinsurance recoveries on new PPOs. There were four new approved claims that are due to be settled by PPO awards.

A. Business and performance continued

Underwriting performance for income protection insurance is considered immaterial to the Group and there are no significant movements between periods. Income protection insurance is no longer sold and is in run-off.

A.3 Investment performance

Investment return

Group

For the year ended 31 December	2017 £m	2016 £m
Investment income	167.1	167.9
Hedging to a sterling floating rate basis	(27.0)	(17.1)
Net investment income	140.1	150.8
Net realised and unrealised gains excluding hedging	35.3	20.7
Total investment return	175.4	171.5

UKI

For the year ended 31 December	2017 £m	2016 £m
Investment income	163.5	163.7
Hedging to a sterling floating rate basis	(27.0)	(17.1)
Net investment income	136.5	146.6
Net realised and unrealised gains excluding hedging	35.4	25.6
Total investment return	171.9	172.2

The Group's investment strategy is to seek to match duration of its UK liabilities and protect the Group's capital. To avoid over-concentration in the limited credit market the Group invests in US and some global investment-grade credit. The Group uses derivatives to hedge all the currency and most interest rate risk back to a sterling floating rate basis, and as a result benefits from credit diversification while hedging to a UK interest rate exposure.

Investment income remained broadly stable year on year with the Group generating £167.1 million, primarily from UKI (£163.5 million). The Group recognised net realised and unrealised gains of £8.3 million, with UKI generating £8.4 million, as a result of higher net realised debt security disposals and unrealised investment property gains partially offset by an increase in hedging costs (driven by widening interest rates between the UK and US) and an impairment of £9.5 million within loans and receivables. At the year end, the net available for sale ("AFS") reserve for the Group was £80.2 million, whilst UKI's AFS reserves were £67.9 million.

Investment yield

Group

For the year ended 31 December	2017	2016
Investment income yield ¹	2.5%	2.5%
Investment return, yield ²	2.6%	2.6%

UKI

For the year ended 31 December	2017	2016
Investment income yield ¹	2.6%	2.5%
Investment return yield ²	2.7%	2.7%

Notes:

1. The income earned from the investment portfolio divided by the average assets under management ("AUM"). This excludes unrealised and realised gains and losses, impairments, and fair value adjustments. The average AUM derives from the period's opening and closing balances for the total Group.
2. The return earned from the investment portfolio divided by the average AUM. This includes unrealised and realised gains and losses, impairments, and fair value adjustments.

A. Business and performance continued

Investment income by asset class

Group

For the year ended 31 December	2017 £m	2016 £m
Investment AFS credit	109.2	104.9
Investment grade held-to-maturity private placements	2.4	1.4
High yield	19.7	17.8
Credit	131.3	124.1
Securitised credit	–	3.5
Sovereign	6.2	8.9
Total debt securities	137.5	136.5
Infrastructure debt	6.8	7.8
Cash and cash equivalents	3.0	4.2
Commercial real estate loans	3.6	1.0
Investment property	16.2	18.4
Total investment income	167.1	167.9

UKI

For the year ended 31 December	2017 £m	2016 £m
Investment AFS credit	109.2	104.9
Investment grade held-to-maturity private placements	2.4	1.4
High yield	19.7	17.8
Credit	131.3	124.1
Securitised credit	–	3.5
Sovereign	3.8	6.0
Total debt securities	135.1	133.6
Infrastructure debt	6.8	7.8
Cash and cash equivalents	2.5	3.4
Intercompany loan income	0.2	0.6
Commercial real estate loans	3.6	1.0
Investment property	15.3	17.3
Total investment income	163.5	163.7

Investment expenses

Group

For the year ended 31 December	2017 £m	2016 £m
Total investment expenses	12.5	14.2

UKI

For the year ended 31 December	2017 £m	2016 £m
Total investment expenses	12.5	14.2

Gains and losses recognised in equity

Group

For the year ended 31 December	2017 £m	2016 £m
Fair value gains on AFS investments	8.8	119.6
Less: realised net gains on AFS investments included in income statement	(23.2)	(15.3)
Tax relating to items that may be reclassified	2.5	(17.6)
Movement in AFS reserves during the year	(11.9)	86.7

A. Business and performance continued

UKI

For the year ended 31 December	2017 £m	2016 £m
Fair value gains on AFS investments	11.2	121.5
Less: realised net gains on AFS investments included in income statement	(17.9)	(5.5)
Tax relating to items that may be reclassified	0.9	(20.0)
Movement in AFS reserves during the year	(5.8)	96.0

Investment in securitised credit

The Group has not held any securitised credit assets within the investment portfolio since disposing of the asset class in September 2016.

A.4 Performance of other activities

Instalment and other operating income

Group

For the year ended 31 December	2017 £m	2016 £m
Instalment income	116.4	107.1
Other operating income:		
Vehicle replacement referral income	16.9	14.1
Revenue from vehicle recovery and repair services	11.3	19.3
Legal services income	11.0	11.2
Other income ¹	23.7	13.6
Other operating income	62.9	58.2
Total	179.3	165.3

Note:

1. Other income primarily relates to salvage income and fee income from insurance intermediary services.

UKI

For the year ended 31 December	2017 £m	2016 £m
Instalment income	116.4	107.1
Other operating income:		
Vehicle replacement referral income	16.9	14.1
Other income	6.1	4.8
Other operating income	23.0	18.9
Total	139.4	126.0

Group instalment and other operating income of £179.3 million shows an increase on the prior year. Instalment income increased primarily as a result of higher Motor volumes.

Operating leasing commitments where the Group / UKI is the lessee

The Group and UKI have entered into non-cancellable operating lease agreements for properties, vehicles and other assets.

Group

	2017 £m	2016 £m
Lease payments under operating leases recognised as an expense in the year	18.8	18.3

UKI

	2017 £m	2016 £m
Lease payments under operating leases recognised as an expense in the year	11.5	11.6

A. Business and performance continued

The following tables analyse the outstanding commitments for future minimum lease payments under non-cancellable operating leases by the period in which they fall due.

Group

	2017 £m	2016 £m
Within one year	19.2	17.4
In the second to fifth years inclusive	58.1	54.2
After five years	154.8	159.7
Total	232.1	231.3

UKI

	2017 £m	2016 £m
Within one year	11.8	11.6
In the second to fifth years inclusive	44.6	45.0
After five years	150.0	155.3
Total	206.4	211.9

Operating commitments where the Group / UKI is the lessor

The following tables analyse future aggregate minimum lease payments receivable under non-cancellable operating leases in respect of property leased to third-party tenants.

Group

	2017 £m	2016 £m
Within one year	15.3	16.3
In the second to fifth years inclusive	46.1	53.0
After five years	73.1	78.9
Total	134.5	148.2

UKI

	2017 £m	2016 £m
Within one year	14.8	15.6
In the second to fifth years inclusive	45.8	52.4
After five years	72.8	78.5
Total	133.4	146.5

A.5 Any other information

Other regulatory changes

On 20 March 2018 the UK Government announced that the Civil Liabilities Bill will be introduced into the House of Lords. The Bill would, if enacted as proposed, introduce measures to tackle whiplash claims as well as bringing forward changes to the way the personal injury discount rate is set. The whiplash measures in the Bill would set fixed amounts of compensation for whiplash claims; introduce a regulatory ban on settling whiplash claims without medical evidence; and provide for the Judiciary to increase the compensation payable in exceptional circumstances.

Section B:

System of governance

(unaudited)

In this section:

Introduction: Assessment of the adequacy of the Group's system of governance

B.1 General information on the system of governance

B.2 Fit and proper requirements

B.3 Risk management system, including the Own Risk and Solvency Assessment

B.4 Internal control system

B.5 Internal audit function

B.6 Actuarial function

B.7 Outsourcing

B.8 Any other information

B. System of governance

This section provides information regarding the system of governance of the Group. References to Group include the Group's regulated insurance companies, UKI and CIC.

Assessment of the adequacy of the Group's system of governance

The Board is responsible for ensuring there is an appropriate system of governance in operation throughout the Group. This includes a robust system of internal controls and a sound risk management framework.

The Group has adopted a High Level Control and System of Governance Framework document which has been approved by the Boards as a statement of the governance structure and requirements applicable to the Company and the Group.

The Board has established a risk management model that separates the Group's risk management responsibilities into Three Lines of Defence. An explanation of these responsibilities can be found on page 43.

During the year the Board approved the Group's Own Risk and Solvency Assessment ("ORSA") following detailed review and challenge to management by the BRC. The Risk Management Committee ("RMC"), which consists of senior executives of the Group responsible for its operations and support functions, had considered and reviewed the processes in preparing the ORSA thoroughly.

The conclusions of the 2017 ORSA were taken into consideration by the Board and Executive Committee in assessing the Group's risk and capital profile related to the Group's annual strategic plan. The 2017 ORSA report summarised four key areas relating to the Plan:

- key assumptions and dependencies;
- prominent and increasing risks;
- forecast capital and solvency position on a Solvency II basis; and
- stress test of the Plan.

The 2017 ORSA report contained additional information including an assessment of: non-quantifiable risks, appropriateness of the standard formula, technical provisions and the outcomes of stress and scenario tests and reverse stress tests.

The Group undertakes a Control Environment Certification process on an annual basis, in which each business area conducts a review of the effectiveness of its risk management and internal control systems and reports to stakeholders that it has done so. This process involves each business area completing a self-assessment of its risks, which is reviewed and challenged by the RMC and the BRC.

Group Audit undertook an annual assessment of the governance, risk management and control environment for the 12 months ended 31 December 2017, which was reviewed by the Audit Committee in February 2018 before the Group's Annual Report & Accounts 2017 were approved by a duly authorised Committee of the Board on 26 February 2018. As part of the end of year process:

i) The Audit Committee noted that following the review of the adequacy and effectiveness of the Group's internal financial controls and internal control systems; no issues had been identified that could be considered to represent:

- material systemic control weaknesses or breakdowns;
- material fraud or irregularities;
- prolonged exposure to material control weaknesses through management failure to remediate control weaknesses on a timely basis;
- material control issues where the root cause is indicative of significant management negligence or incompetence; or
- evidence of repeat occurrence of material issues arising from a failure on the part of management to deliver fully robust remediation.

ii) The BRC noted that the BRC's review of the adequacy and effectiveness of the Group's risk and governance framework, including risk appetite, risk exposures and the identification, monitoring and management of risk and control issues had not identified any issues which could be considered to represent:

- material or systemic weaknesses or breakdown in the systems of governance or ERMF;
- material or extended breaches of the Group's approved risk appetite or related authorities, limits and mandates;
- material regulatory breaches or notifications;
- material risk to the Group's reputation; or
- evidence of repeat occurrence of material issues arising from a failure on the part of management to deliver fully robust remediation.

B. System of governance continued

The Group has identified certain principal risks as being applicable to the Group, for example as referred to in the ORSA and as summarised in the Group's Annual Report & Accounts 2017, and assesses robustly those principal risks. The Board sets and monitors adherence to the risk strategy, risk appetite and risk framework. Within this overall context, the Board has over time approved a system of governance which is referred to in the High Level Control and System of Governance document and which includes the Matters Reserved to the Board, the Board Committees' terms of reference, the Regulatory Governance Map, risk appetite statements, the ERMF, Group policies and minimum standards.

B.1 General information on the system of governance

The Boards

The Boards are comprised of the same persons and act as the Administrative, Management or Supervisory Body.

For details of the Company's board visit the Group's corporate website at www.directlinegroup.com/aboutthe-group/board-and-leadership/board

The Board has a collective objective of promoting the long-term success of the Company for its shareholders and provides leadership of the Company. The Board's specific duties are set out in the Schedule of Matters Reserved for the Board, which contains items reserved for the Board to consider and approve, relating to strategy and management, contracts, financial reporting and controls, internal controls and risk management, Board membership and succession planning, corporate governance, structure and capital, delegation of authority and remuneration. In addition to the schedule of Matters Reserved, each Board Committee has written terms of reference defining its role and responsibilities.

Details regarding Board meetings and Board activity during 2017 can be found on pages 52 and 53 of the Group's Annual Report & Accounts 2017 at www.directlinegroup.com/investors

Structure of the Board, Board Committees and executive management

A summary of the role of the Board, its six Committees (Audit Committee, Board Risk Committee ("BRC"), Nomination Committee, Remuneration Committee, Corporate Social Responsibility Committee and Investment Committee) and the responsibilities of the Chairman, the CEO and executive management can be found on pages 50 and 51 of the Group's Annual Report & Accounts 2017 at www.directlinegroup.com/investors

The terms of reference of the Audit Committee, the BRC, the Nomination Committee and the Remuneration Committee are available at www.directlinegroup.co.uk/termsreference

The terms of reference of the Corporate Social Responsibility and Investment Committees are available on request from the Company Secretary.

The Board is responsible for ensuring there is an appropriate system of governance in operation throughout the Group. This includes a robust system of internal controls and a sound risk management framework.

The Group's governance framework is detailed in the Group's High Level Control and System of Governance Framework document. This document, together with the Regulatory Governance Map, details how the Group meets Solvency II and PRA requirements to identify Key Functions, to have and maintain a Governance Map and the requirements in respect of the PRA Senior Insurance Managers Regime and the Financial Conduct Authority ("FCA") Approved Persons regime. The Board reviews these documents annually.

The core elements of the Governance Framework are the:

- Matters Reserved for the Board and the Board Committees' Terms of Reference;
- High Level Control and System of Governance Framework document;
- Regulatory Governance Map;
- risk appetite statements;
- ERMF, which sets out the Group's approach to setting risk strategy and for managing risks to the strategic objectives and day-to-day operations of the business;
- Executive Governance Framework, which outlines how each business function is governed and details the authority delegated to Executive Committee members;
- Group policies, which address specific risks areas and inform the business how it needs to conduct its activities to remain within risk appetite; and
- Minimum standards, which interpret the Group policies into a set of operational requirements that can be implemented throughout the Group.

Further details regarding the split of responsibilities for the different parts of the Group's governance framework can be found on page 54 of the Group's Annual Report & Accounts 2017 at www.directlinegroup.com/investors

B. System of governance continued

Solvency II Key Functions

Set out below is a diagram highlighting the day-to-day reporting lines of the Key Functions as required by the Solvency II Directive:

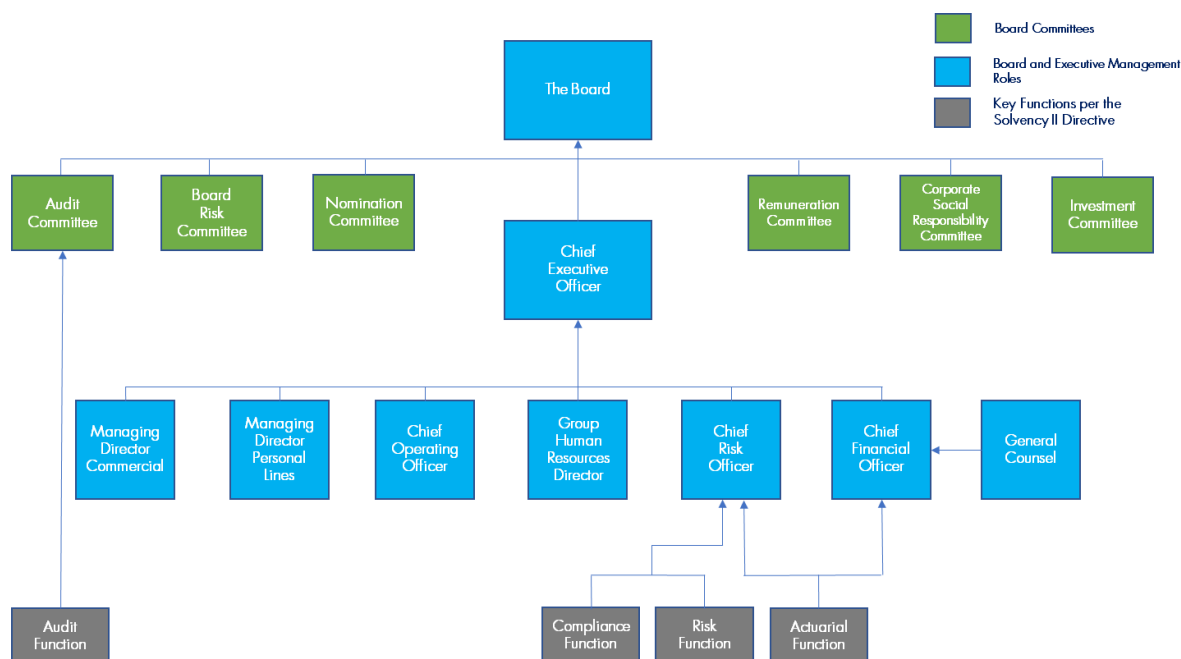

Note:

The responsibilities of the Actuarial function holder are split between the Actuarial Director and the Director of Financial Risk

Further information on the authority, resources and the independence of the four Solvency II Key Functions identified above is set out in sections B.3 to B.6 of this report.

Those working in the Solvency II Key Functions are subject to the provisions of the Fit and Proper Minimum Standard (see section B.2) which requires them to have the necessary skills, knowledge and experience to fulfil their position. This is assessed both on initial appointment and through annual performance appraisals.

Material changes in the system of governance

There have been no material changes to the Company's system of governance during the reporting period.

Information on remuneration policy and practices

Introduction

The Group believes that employees are critical to the success of the Group's business, both now and into the future. As a result, the Group's remuneration policy aims to provide, in the context of the Group's business strategy, an attractive reward proposition at the right cost to attract, retain, motivate and reward high calibre employees so that they are engaged to deliver superior long-term business performance within acceptable risk parameters and having due regard to all relevant regulatory guidance.

Executive Directors: principles of remuneration policy

The Directors' remuneration policy was most recently approved at the Company's AGM on 11 May 2017. The policy provides a clear and simple framework for remuneration of the Company's Directors, and aligning the Executive Directors' variable pay opportunities to the business strategy and achievement of the Company's performance indicators.

B. System of governance continued

The table below summarises the implementation of the elements of Executive Directors' remuneration in 2017.

Key features	Implementation in 2017
<p>Base salary Reviewed annually with any increases taking effect on 1 April. The Committee considers a range of factors when determining salaries, including pay increases throughout the Group, individual performance and market data.</p>	<p>The increases to Executive Directors' salaries in 2017, effective 1 April 2017, reflected the average increase awarded to UK employees in 2017.</p>
<p>Pensions and benefits CEO, Chief Financial Officer ("CFO") and CFO-designate pension contribution rate of 25% of salary. Managing Director, Personal Lines pension contribution rate of 15% of salary. Benefits comprise providing a company car or car allowance, private medical insurance, life assurance, income protection and health screening. Like all employees, the Executive Directors are also eligible for certain discounted Group products.</p>	<p>No change from 2016.</p>
<p>Annual Incentive Plan ("AIP") Maximum opportunity at 175% of salary for the CEO and CFO-designate and 150% for the other Executive Directors; 40% of the award is deferred into shares, typically vesting after three years. At least 50% of bonus is based on financial measures. The Committee considers various non-financial and strategic performance measures. It bases its judgement on the payment outcome at the end of the performance period on its assessment of the level of stretch inherent in targets. Any payment is subject to an additional gateway assessment, including assessing risk factors. Malus and clawback conditions apply.</p>	<p>For 2017 the weightings of the measures were as follows:</p> <ul style="list-style-type: none"> • Financial metrics – 55%: Profit before tax • Strategic – 25%: based on a basket of: <ul style="list-style-type: none"> - customer measures, including Net Promoter Score and complaints - people measures, including measures of gender diversity and engagement • Personal – 20%: objectives for each Executive Director, including shared objectives across the Executive Committee
<p>Long-Term Incentive Plan ("LTIP") Awards typically granted as nil-cost options. Awards typically granted every six months at half the annual level. The Plan allows for awards with a maximum value of 200% of base salary per financial year. Performance is measured over three years and determined by Return on Tangible Equity ("RoTE") and relative Total Shareholder Return ("TSR") measures. Awards vest subject to financial underpin and payment gateway. Malus and clawback conditions apply. Awards are subject to an additional two-year holding period following the end of the three-year performance period.</p>	<p>For 2017 awards the performance conditions were:</p> <ul style="list-style-type: none"> • RoTE - 60% weighting • TSR - 40% weighting <p>Return on Tangible Equity condition:</p> <ul style="list-style-type: none"> • measured over financial years 2017, 2018 and 2019 • average annual RoTE of 15% – 20% of this portion vests • average annual RoTE of 16% – 40% of this portion vests • average annual RoTE of 18% – 100% of this portion vests • straightline vesting between these levels <p>Relative Total Shareholder Return condition:</p> <ul style="list-style-type: none"> • measured over 3 years from date of award • measures TSR relative to FTSE 350 (excluding investment trusts) • median ranking – 20% of this portion vests • upper quintile ranking – 100% of this portion vests • straightline vesting between these levels <p>Underpin: The LTIP awards will only vest if the Committee is satisfied in relation to the Group's underlying financial performance. The Committee will also consider whether there have been any material risk failings.</p>
<p>Shareholding guidelines</p>	<p>All Executive Directors are subject to a shareholding guideline of 200% of base salary.</p>

B. System of governance continued

Non-Executive Directors: principles of remuneration policy

Non-Executive Directors ("NEDs") are paid a basic annual fee. Additional fees may be paid to NEDs who chair a Board Committee, sit on a Board Committee, and for the Senior Independent Director to reflect additional responsibilities, as appropriate.

The fees paid to the Chairman include all Board and Committee membership fees, and are determined by the Remuneration Committee.

NEDs may receive certain expenses, including the reimbursement of travel expenses and accommodation or similar which, consistent with general market practice, will be grossed-up for any tax arising on such expenses.

Reward for employees: principles of remuneration policy

The Group has one consistent reward policy for all levels of employees. Therefore, the same reward principles guide reward decisions for all Group employees, including Executive Directors. However, remuneration packages differ to account for appropriate factors in different areas of the business:

- **AIP** – approximately 3,600 employees participate in the AIP. The corporate performance measures for all employees are consistent with those used for Executive Directors, although the weighting attributable to those factors may differ. The Group's strategic leaders (approximately 60 employees) also receive part of their bonus in Company shares deferred for three years;
- **Incentive awards** – approximately 3,800 employees, excluding Executive Directors, participate in a function or team specific incentive plan which assesses personal performance over a monthly period. These incentive awards may pay out monthly or quarterly;
- **LTIP** – The Group's strategic leaders participate in the LTIP, currently based on the same performance conditions as those for Executive Directors;
- **Restricted Share Plan ("RSP")** – RSP awards are used on a limited basis across the Company to help recruit and retain critical staff, and for talent management. Executive Directors do not receive grants under the RSP;
- **All employee share plans ("SIP")** – the Committee considers it important for all employees to have the opportunity to become shareholders in the Company. The HMRC-approved SIP has operated since 2013, and, in addition, the Company has made periodic awards of free shares. At year-end, approximately 3,000 employees throughout the Group had signed up to these schemes with 9,500 holding free shares in the Company; and
- **Pension and benefits** – depending on employee grade, the Company contributes between 9% and 25% to the defined contribution pension scheme without any requirement for an employee contribution. Employees may also opt for a proportion or all of this to be paid as cash rather than into the pension scheme.

Relative importance of fixed and variable pay

The Company ensures that the fixed and variable remuneration components of remuneration are appropriately balanced, with the fixed portion representing a sufficiently high proportion of total remuneration which allows the operation of a fully flexible policy on variable remuneration components including the possibility to pay no variable remuneration component. Fixed pay comprises base pay, benefits and pension. Fixed pay is set to be competitive against market levels. The Company monitors both the ratio of fixed to variable pay and quantum against the market. In no cases are the fixed components of pay set at levels which would then require undue reliance on incentive pay elements for living costs.

Supplementary pension or early retirement schemes

There are no supplementary pension or early retirement schemes in place for the Board or other Key Function Holders during the reporting period.

B. System of governance continued

Material transactions

On 27 April 2012, the Company issued subordinated guaranteed dated notes with a nominal value of £500 million at a fixed rate of 9.25%. On 7 December 2017, the Company issued £350 million of Perpetual NC10 Restricted Tier 1 ("RT1") notes with a coupon of 4.75%. The proceeds of this issuance were primarily used to fund the tender of half the Company's £500 million 30NC10 9.25% Tier 2 debt (the "Tier 2 debt"). On 8 December 2017, the Company completed the repurchase of £250 million nominal of the Tier 2 debt. The remaining £250 million (nominal) of Tier 2 debt has a first call date of 27 April 2022 and is guaranteed by UKI.

On 27 April 2012, the Company advanced a £500 million unsecured subordinated loan to UKI at a fixed rate of 9.5% with a repayment date of 27 April 2042. There is an option to repay the loan on specific dates from 27 April 2022.

CIC has a 100% quota share reinsurance treaty with UKI to recover insurance liabilities that are not satisfied by third-party reinsurers. As at 31 December 2017, the amount of the reinsurance recoverable from UKI was £13.1 million.

B.2 Fit and proper requirements

Skills, knowledge and expertise of the persons who run the Group or Key Functions

The individuals were appointed to their roles following due diligence with the objective of ensuring that they had the necessary competence and were fit and proper to fulfil their positions. In making these assessments of competence due consideration was given to the individuals':

- professional qualifications, knowledge and experience to enable sound and prudent management (fit);
- character, in that they were of good repute and integrity (proper); and
- appearance on the public financial services register, where the person is an Approved Person.

To support effective operation of this requirement, the Group requires Approved Persons or Key Function Holders to:

- comply and meet the PRA Insurance Conduct Standards and FCA Conduct Rules, in respect of roles undertaken for UKI and CIC;
- comply with the requirements expected of Approved Persons or Key Function Holders to meet as set out in the Group's Regulatory Compliance Risk Policy, Fit and Proper Minimum Standard and Interaction with Regulators Minimum Standard;
- manage risks and controls that are reflected in their role profiles in accordance with the ERMF and as set out in the Group's Regulatory Governance Map; and
- continue to pass the fit and proper self-assessment as part of the Approved Persons' annual review.

Process for assessing fitness and propriety of Approved Persons

The individuals are subject to the Group's Regulatory Compliance Risk Policy which has its own specific minimum standard relating to the fitness and propriety of those persons who hold regulatory accountabilities. The minimum standard requires that individuals should notify their own line manager and the Director of Group Regulatory Risk and Compliance, if there is any matter that may impact directly or create a perception of impacting on their ongoing fitness and propriety. The Compliance function would notify the regulator if there is information that would be expected to be material to the assessment of their fitness and propriety.

As well as being subject to ongoing formal reviews of their performance in their role, the individuals are also subject to the Group's annual self-declaration assessment of fitness and propriety. To support effective operation of this requirement, the Group:

- ensures that all Approved Persons / Key Function Holders have an up-to-date role profile which is signed by both the individual and their line manager;
- ensures that role profiles for all Approved Persons and Key Function Holders correctly reflect the regulatory accountabilities they hold, and includes an up-to-date structure chart;
- ensures that all individuals who have been an Approved Person or Key Function Holder for the Group for more than six months have submitted to Compliance their return from the last annual declaration of fitness and propriety; and
- ensures the Approved Person / Key Function Holder has evidence on file to show that their training needs have been kept under review, in particular that the actions they have taken regarding training are recorded within their ongoing performance reviews and within development plans.

B. System of governance continued

B.3 Risk management system, including the Own Risk and Solvency Assessment

Risks are managed on a Group-wide basis for the regulated insurance companies, UKI and CIC, and the Group as a whole, as risks faced by the Group, UKI and CIC are similar in nature and scope. References to Group also include the Group's regulated insurance companies, UKI and CIC.

The Board sets and monitors adherence to our strategy, risk appetite and risk framework. The Group has established an ongoing process for assessing the principal risks facing the Group, and monitoring the effectiveness of the Group's risk management systems.

The ERMF document sets out, at a high level, the Group's approach to setting risk strategy and managing risks. It documents the high-level principles and practices to achieve appropriate risk management standards and demonstrates the inter-relationships between components of the ERMF.

The ERMF is designed to enable the Group to manage the business with the necessary understanding of its risks and controls, as well as having appropriate oversight in place to manage risks proactively. The ERMF is aligned to the Three Lines of Defence model and provides a comprehensive approach for managing all principal risks across the Group. A central component of the ERMF is the Policy Framework, which includes policies and minimum standards. Policies address specific risk areas and are aligned to the Group's risk appetite. Policies where appropriate are supported by underlying minimum standards which interpret policies into a set of risk and control requirements to be implemented across the Group. The Group has an annual review programme to ensure that the ERMF, policies and minimum standards remain fit for purpose.

Risk strategy and appetite

The Group's risk appetite statements define the risks the Group is prepared to accept in the pursuit of achieving its strategic objectives. Risk appetite statements are supported by key risk indicators ("KRIs") designed to provide an early warning that appetite may be breached without remedial action being taken.

These KRIs are both qualitative and quantitative, and forward- and backward-looking. The Group reviews its risk appetite statements and KRIs annually.

The table below outlines the Group's risk objectives and risk appetite statements:

Risk objective	Risk appetite statement
Overarching risk objective	The Group recognises that its long-term sustainability depends on having sufficient economic capital to meet its liabilities as they fall due, thus protecting its reputation and the integrity of its relationship with policyholders and other stakeholders. As part of this, the Group's appetite is for general insurance risk, focusing on personal lines retail and SME insurance in the UK. The Group has appetite for non-insurance risks, as appropriate, to enable and assist it to undertake its primary activity of insurance.
1. Maintain capital adequacy	The Group seeks to hold own funds in the range of 140% to 180% of the internal model SCR. The Group also seeks to maintain sufficient economic capital consistent with its strategic aim of maintaining a credit rating in the 'A' range.
2. Stable and efficient access to funding and liquidity	The Group aims to meet both planned and unexpected cash outflow requirements, including those requirements that arise following a 1-in-200 years insurance, market or credit risk event.
3. Maintain stakeholder confidence	The Group has no appetite for material risks resulting in reputational damage, regulatory or legal censure, poor customer outcomes, fines or prosecutions, and other types of non-budgeted operational risk losses associated with the Group's conduct and activities. The Group will maintain a robust and proportionate internal control environment.

B. System of governance continued

Risk management process

The risk management process enables the Group and its regulated insurance companies to manage risk in a structured and consistent way.

The potential impacts of all risks, events and management actions are rated using an Impact Classification Matrix which facilitates a consistent approach to the sizing and categorisation across the Group. All risks are mapped to the Group risk taxonomy to support effective risk management and reporting across the business.

The risk management process is summarised below:

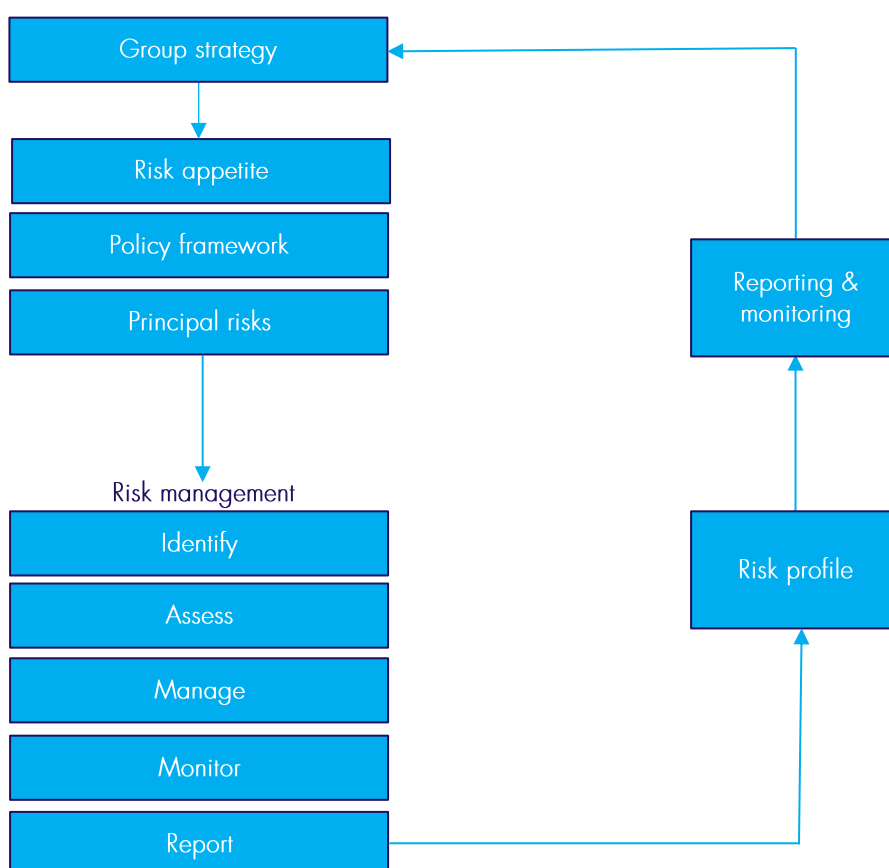

- Identify – identification of current and emerging risks, including risks presented through the implementation of change, which could impact on the achievement of business strategic objectives. Identification should utilise expert judgement, historic data, external data, forward-looking analysis and models.
- Assess – assessment of risks on an inherent and residual basis in terms of potential severity of impact and likelihood of occurrence. Assessments may be reached using quantitative or qualitative measures.
- Manage – management of residual risk exposure within risk appetite through the implementation of mitigating actions. Under exceptional circumstances management may explicitly accept the risk exposure outside of appetite in line with the Group’s defined Risk Acceptance process. Action plans are used throughout the Group to ensure residual risk exposure is maintained at or brought back within risk appetite, to address control weaknesses or manage remediation (where required) following an event.
- Monitor – monitoring of risk exposure using KRIs and to ensure management actions are being delivered. The approach and frequency of risk monitoring depends on the nature of the risk and management judgement.
- Report – regular reporting of an accurate, clear and timely assessment of the risk profile and progress with management actions. Escalation of notable changes to risk profile to relevant committees and fora. RAG statuses and Risk Outlook indicators (set out in the Directorate Risk Management Minimum Standard) are used in risk-related reports across the Group.

B. System of governance continued

Implementation and integration of risk management system into the organisational structure and decision-making processes

Clear risk governance helps the Group with its objective of ensuring that risk management arrangements are effective. The Group Board delegates authority for risk management to the CEO, who then further delegates to the members of the Executive Committee. The Chief Risk Officer (“CRO”), who chairs the RMC, has accountability for providing risk oversight.

The Group’s risk governance arrangements include Three Lines of Defence accountabilities and the risk management responsibilities of the Board, the BRC and RMC. The Group ensures comprehensive risk management through its Three Lines of Defence model described above.

Own Risk and Solvency Assessment

The ORSA process incorporates several underlying key processes and tools within the Group’s ERMF which are used to manage risk and capital. These underlying processes and tools are reviewed periodically throughout the year at various governance committees enabling frequent and localised decision making.

The ORSA is facilitated by the Enterprise Risk Team and supported by teams within Finance and Risk. Outcomes of the ORSA are taken into consideration by the Executive Committee. The ORSA report is presented to the Board for challenge and the conclusions are taken into consideration in assessing the Group’s risk and capital profile related to the strategic plan. The agreed outcomes and conclusions of the ORSA are approved by the Board.

The ORSA report is also a supervisory tool and, as such, is used to explain to the relevant supervisory body the current and forecast capital and solvency position of the Group throughout the strategic plan period.

Risk management system for the internal model

Governance of the Internal Economic Capital Model

The governance of the IECM is documented in the Internal Economic Capital Model Policy, associated minimum standards and guidance notes. These documents form part of the Group’s Enterprise Risk Policy and Minimum Standard Framework and describe the responsibilities of individual roles and committees in the governance of the IECM. The IECM Policy is designed to ensure the appropriate control and management of model risk in relation to the IECM, it is reviewed annually and approved by the Board.

Responsibility for the delivery of the IECM is delegated throughout the business in a manner that ensures:

- appropriately skilled resources are responsible for the design and operation of the IECM;
- governance is effective and transparent; and
- the business is engaged in the direction and use of the IECM and there is robust independent challenge of the design and operation of the IECM.

The following minimum standards support the IECM Policy:

- Model Scope and Aggregation which sets out the scope of the IECM and the approach to aggregation and calculation of the Group PIM;
- Model Validation which is the Model Validation Policy for Solvency II purposes;
- Model Change which is the Model Change Policy for Solvency II purposes;
- Model Documentation;
- Model Use; and
- Model Compliance.

The Data Quality Minimum Standard also applies to the governance and operation of the IECM.

The Board approved the application to the PRA for internal model approval and authority for specific approvals are reserved for the Board; these are captured in the Model Change Minimum Standard which is the Model Change Policy for Solvency II purposes. The reserved approvals are:

- changes to the agreed scope of the IECM;
- changes to the Model Change Minimum Standard;
- changes to the threshold for Major changes and the accumulation of Minor changes; and
- changes to the model with a Major materiality classification and the application to the PRA to make such changes.

The Board receives regular reports regarding changes to the IECM and use of the IECM and ongoing training to ensure it has an appropriate understanding of the strengths, weaknesses and limitations of the IECM.

B. System of governance continued

The responsible roles and committees and their main tasks and scope of their responsibilities in respect of the IECM are described below:

The BRC:

- reviews all material in respect of the IECM before it is submitted to the Board;
- reviews the IECM scope annually;
- approves the independent validation scope and framework and an executive summary of the annual independent validation report, which contains results and progress of issues raised;
- receives assurance from the Group Head of Audit regarding the independence, adequacy and effectiveness of the validation framework;
- approves high materiality model changes;
- approves the closure of high model issues and limitations; and
- receives regular management information regarding the results and use of the IECM.

The RMC:

- reviews all material in respect of the IECM before it is submitted to the BRC;
- reviews the IECM scope annually; and
- receives regular management information regarding the results, model changes, use and progress of issues and limitations of the IECM.

The CRO:

- is responsible for the independent validation; and
- is responsible for escalating any material non-compliance issues to the Board.

The CFO:

- is the executive sponsor of the IECM.

The Actuarial Director:

- is the owner of the IECM with responsibility for its design and operation;
- is responsible for communicating the development and limitations of the IECM and the requirements of the IECM policy to its users;
- sets out the scope of the IECM;
- ensures profit and loss attribution exercises are completed;
- approves medium materiality model changes;
- approves the closure of medium model issues and limitations;
- ensures the delivery of primary validation; and
- responds to issues presented by the independent validation function to the RMC and BRC, including presentation of a model development plan for resolution of any major issues.

The Head of Economic Capital:

- is responsible for managing the IECM, including production of results, model changes and model issues, and documentation;
- approves low materiality model changes;
- approves the closure of low model uses and limitations;
- selects parameters for the IECM in conjunction with subject matter experts and risk owners from across the Group;
- is responsible for ensuring the model is used across the business and appropriate training is provided to model users; and
- considers issues raised by the independent validation function and ensures that these are appropriately acted upon.

B. System of governance continued

The Head of Validation:

- is responsible for managing the independent validation of the IECM, including production of the validation scope, framework and annual validation report; and
- is responsible for ensuring that validation tests are sufficiently robust and well documented.

Material changes to Internal Economic Capital Model governance

There have been no changes to the governance structure of the IECM over the reporting period.

Validation process of the Internal Economic Capital Model

The Group's Model Validation Minimum Standard has been in effect since August 2010 and is reviewed and updated on an annual basis to reflect changes in emerging practice, Solvency II requirements and structural changes within the Group.

During 2013 to 2015, an external validation of the IECM was performed, including the Tests and Standards for Model Approval. This work was conducted independently and was reported to the Board.

An internal Model Validation team was established within the Risk Management function in 2016, moving full responsibility for the delivery of an independent model validation in-house. Two experienced actuaries were appointed into the roles of Head of Validation and Validation Manager.

During 2018, the in-house Model Validation team completed its third annual cycle of validation, with delivery of the executive summary of the annual validation report to the RMC and BRC in April. The team has also focused on further embedding in-house Model Validation as a business as usual function, which has delivered benefits in terms of proactivity and flexibility.

The Model Validation team gave an overall validation opinion in the annual independent validation report on the IECM version used for the year end 2017 SCR assessment, that nothing material had come to their attention during their testing as part of the validation process that led to them recommending to the BRC on 25 April 2018 that the IECM and the surrounding processes were not a sound basis for the purposes of calculating Regulatory Capital under Solvency II for both UKI and Group.

The Group continues to make use of external resources to support model validation.

The Model Validation Minimum Standard requires the CRO to present the scope of validation activities envisaged for the year, as well as the validation framework to the RMC for noting and the BRC for approval on an annual basis.

The Validation Plan is drafted in line with the Model Validation Framework, which stipulates that the Group will maintain an annual cycle of validation activity and reporting, comprising three key elements:

- an annual programme of core validation testing;
- a rolling programme of 'deep-dives' into specific validation areas to take a deeper look at whether the modelling is fit for purpose and covers regulatory requirements; and
- validation of model changes (including updates to address previous validation issues).

The Model Validation Framework document distinguishes between the key elements that will form part of the annual programme of core validation testing and deep-dives. The deepdives are performed as part of a rolling programme which aims to cover all areas of the model over a three-year time period, but also considers bespoke investigations in response to a thematic review or a current area of interest.

B.4 Internal control system

The Board has established a management structure with defined lines of responsibility and clear delegation of authority. This control framework cascades through the divisions and central functions, detailing clear responsibilities to ensure the Group's operations have appropriate controls. This includes controls relating to the financial reporting process.

The Board, with the assistance of the BRC and the Audit Committee as appropriate, monitored the Company's internal control systems that have been in place throughout the year under review, and reviewed their effectiveness. The monitoring and review covered all material controls, including financial, operational and compliance controls.

The Board was also supported in its review of the annual Control Environment Certification process. As part of this, each directorate self-assessed its risks and whether its key controls were adequate and effective. The Risk and Group Audit functions reviewed and challenged these findings. The Group then combined the overall findings into a Group-level assessment, which the CEO approved. The process included reporting on the nature and effectiveness of the controls, and other management processes that manage these risks.

The Group Audit function supports the Board by providing an independent and objective assurance of the adequacy and effectiveness of the Group's controls. It brings a systematic and disciplined approach to evaluating and improving the effectiveness of its risk management, control and governance frameworks and processes.

B. System of governance continued

The Board acknowledges that any internal control system can manage, but not eliminate, the risk of not achieving business objectives. It can only provide reasonable, not absolute, assurance against material misstatement or financial loss.

On behalf of the Board, the Audit Committee regularly reviews the effectiveness of the Group's internal control systems. Its monitoring covers all material controls. Principally, it reviews and challenges reports from management, the Group Audit function and the External Auditor. This enables it to consider how to manage or mitigate risk in line with the Group's risk strategy.

Key procedures of the internal control system

The Group has established a number of tools to support effective implementation of the internal control system. These include:

- detailed policies and minimum standards which articulate the controls required to manage risks that the Group is exposed to;
- an annual review programme to ensure that policies and minimum standards remain fit for purpose;
- management of risks through risk assessment, action and event management; and
- provision of advice and guidance by minimum standard owners to the First Line of Defence in discharging their responsibilities.

Additionally, the Group has a number of processes that demonstrate the proactive use of the ERMF. These include:

- regular, at least annual, review of the risk appetite framework undertaken by the RMC and recommended by the BRC for approval by the Board;
- formal risk management reporting to the RMC and BRC as well as regular risk reporting from other risk committees and fora;
- the Material Risk Assessment;
- the assessment of Risk Behaviours and Attitudes;
- the ORSA;
- use of the IECM to inform and support decision-making;
- stress testing and scenario analysis; and
- the Control Environment Certification process.

Compliance function

The Compliance function is a Second Line of Defence function, which is responsible for providing advice and guidance to the Group regarding compliance with both conduct and prudential regulatory requirements. The Director of Group Regulatory Risk and Compliance, who is approved by the FCA, is responsible for the Compliance function. The Compliance function works with colleagues from across the Risk Management function and management throughout the business to fulfil this responsibility.

The Regulatory Compliance Risk Policy, Conduct Policy, Fraud and Financial Crime Policy and associated minimum standards outline the role of the function. These policies, approved by the Board, provide the high-level requirements to ensure that the business remains compliant with supporting minimum standards. Other areas of compliance risk are covered by a number of separate policies and minimum standards on specific topics, such as information security and a range of policies on prudential issues. All Compliance employees are required to undertake annual online training of relevant subject areas.

In addition to the policies and minimum standards, the Compliance team undertakes the following with the objective of ensuring compliance with regulatory requirements:

- attendance at and chairmanship of governance fora; for example, the Financial Crime Steering Committee, Conduct Regulatory Risk Forum, Operational Risk Committee, Customer Conduct Committee, RMC and BRC;
- monitor regulatory developments and report areas of interest to management and the Boards;
- risk dashboards and monitor adherence to risk appetite through the tracking of KRIs;
- incident management;
- advice and guidance;
- training;
- control environment certification process;
- assurance and effectiveness reviews undertaken by the Compliance and Conduct Assurance team; and
- regulatory reviews, including thematic reviews.

B. System of governance continued

B.5 Internal audit function

Group Audit helps and supports the Board and Executive Committee in their aim to: protect the assets, reputation and sustainability of the Group; achieve their strategic and operational objectives; and discharge their corporate governance responsibilities. Group Audit achieves this by:

- providing assurance that the risk management processes and controls established by management are adequate, effective and sustainable to manage key business risks, including reviewing any 'lessons learned' analysis if a significant event has occurred;
- assessing whether all significant risks are identified by management and the Risk function and reported to the Board and the Executive Committee;
- challenging the Executive Committee to improve governance, risk management and control activities, including challenging the definition and monitoring of risk appetite performed by the Risk function;
- challenging processes and controls that support strategic and operational decision-making and assessing the appropriateness and reliability of management information presented to the Board and Executive Committee;
- providing a Group-wide view of specific risk and control themes emerging from Group Audit work, including considering current and emerging factors and how business processes support a customer focus and compliance with conduct requirements;
- in conjunction with the Risk function, offering an assessment of management's risk behaviours and attitudes;
- when considered appropriate or on request, providing assurance over key corporate events, such as new products and services, outsourcing, acquisitions or divestments; and
- being available to the Board, as required, to provide an independent investigations service, for example in those circumstances where it would be inappropriate for the Risk function to undertake an investigation.

Group Audit presents a quarterly report to the Audit Committee summarising the results and analysis of audit activity in the preceding quarter. On an annual basis, Group Audit also presents a report, which provides (i) an independent opinion on the Group's self-assessment of the Group-wide control environment; (ii) an analysis of key themes and trends identified from audit work performed in the period; (iii) an assessment of the ERMF; and (iv) an assessment of management's risk behaviours and attitudes. Group Audit is not part of the system of risk control or compliance, and does not:

- take accountability for the risk management framework and processes;
- represent Executive Committee's assurance on risks; or
- take decisions on risk mitigation or implement risk mitigation actions on behalf of Executive Committee.

Independence and objectivity of internal audit

To both preserve and reinforce Group Audit's independence and objectivity, the primary reporting line for the Group Head of Audit is to the Chair of the Audit Committee who is an independent NED. The Audit Committee is responsible for the appointment and removal of the Group Head of Audit. The Chair of the Audit Committee sets objectives for the Group Head of Audit and recommends remuneration for the Group Head of Audit to the Remuneration Committee. The Group Head of Audit communicates and interacts directly with the Audit Committee and with members of the Committee in between Committee meetings or where escalation is required.

The Group Head of Audit also maintains a reporting line to: the Group CEO, to report on the outcome of audit activity and assessments on the Group control environment; and the Group CFO, for day-to-day administrative purposes, although these administrative purposes do not include any matters that could influence Group Audit in delivering its mandate.

It is imperative that Group Audit's independence and objectivity are maintained through being exempt from undertaking any executive or operational duties, or any other activity, that may impair Group Audit's judgement. Group Audit remains free from interference by any element in the Group, including matters of audit selection, scope, procedures, frequency, timing or report content to permit maintenance of independence and objectivity. The Group Head of Audit confirms to the Audit Committee, at least annually, the organisational independence of Group Audit.

B.6 Actuarial function

The Actuarial function for the Group encompasses both First and Second Lines of Defence activities and has been split between two Actuarial function holders.

Reserving and calculation of technical provisions is co-ordinated and performed by the First Line of Defence Actuarial function. Actuarial risk management, including opinions on underwriting and reinsurance is conducted by the Second Line of Defence. The Actuarial Director and the Director of Financial Risk are the two chief actuaries for the Group and fulfil the First and Second Lines of Defence responsibilities respectively.

B. System of governance continued

The First Line of Defence Actuarial function meets the requirements of Solvency II with the following activities undertaken during the reporting period:

- co-ordinating the calculation of technical provisions;
- ensuring the appropriateness of methodologies used in the calculation of technical provisions;
- assessing the sufficiency and quality of data used in the calculation of technical provisions;
- comparing best estimates against experience; and
- informing Group management of the reliability and adequacy of technical provisions.

The Second Line of Defence Financial Risk function meets the requirements of Solvency II with the following activities undertaken:

- expressing an opinion on the overall underwriting policy;
- expressing an opinion on the adequacy of reinsurance arrangements; and
- contributing to the effective implementation of the risk management system, in particular with respect to the risk modelling underlying the calculation of the capital requirements, and to the ORSA.

The contribution to the effective implementation of the risk management system is additionally met by the First Line of Defence Actuarial function through the supply of technical provisions to the IECM and the balance sheet.

Both the First and Second Line of Defence functions are sufficiently composed of qualified actuaries to meet the skilled persons' requirement of actuarial functions. The activities of the Actuarial function are documented in the Actuarial Function report and submitted annually to the Board.

B.7 Outsourcing

The Supplier Management and Outsourcing Minimum Standard ensures the Group undertakes a consistent approach to the management of risks from the sourcing and appointment of external suppliers of goods and services in line with the risk appetite set by the Board. The Policy provides a framework within which the Group manages its outsourcing and external supplier risk exposure where external supplier risk is defined as the risk of failing to implement a robust framework for the sourcing, appointment and ongoing contract management of external suppliers, outsourced service providers and intragroup relationships.

This framework details the defined sourcing approach when procuring the services and providing regular oversight of the performance of third parties in relation to key contractual requirements. This is particularly with respect to external suppliers that are deemed to provide a material, critical and important service to the Group and therefore, ultimately, to its customers. These are services of such importance that weaknesses or failure of those services would cast doubt upon the Group's ability to comply with its key regulatory obligations or deliver its services to policyholders and as such processes and activities undertaken within sourcing and contract management have been refined to include requirements specific to these outsourced services.

The First Line of Defence identifies, assesses, manages and monitors all types of outsourcing and external supplier risks in line with the ERMF. Where additional guidance is required in respect of outsourcing and external supplier risk, the Procurement and Supply Chain function is consulted. The Group categorises relationships with external suppliers as follows:

- outsourcing arrangements are those of any kind between the Group and a service provider by which that service provider performs a service or an activity that would otherwise be undertaken by the Group;
- material, critical or important outsourcing arrangements are the outsourcing of a function or activity that is so important that the Group would be unable to deliver its services to policyholders without that function or activity. In the UK, all relevant arrangements must be notified to the appropriate regulator, through the Second Line of Defence Compliance function, in advance of such activity taking effect;
- intragroup outsourcing is the provision of services which are material, critical or important by one entity to another within the same Group; and
- external suppliers are third-party organisations providing goods or services to the Group or directly to the Group's customers on the Group's behalf, but exclude commission payments to brokers.

Where intragroup arrangements are in force, the Supplier Management and Outsourcing Minimum Standard states that the minimum standard owner is to convene a review on an annual basis to ensure that the agreements remain current and reflect the appropriate service provisions and providers. This review, as a minimum, will include representation from the Group Legal, Procurement and Supply Chain, Risk and Compliance functions. The review aims to help ensure that intragroup arrangements are all correctly identified and supported by an appropriate agreement, and any changes required given the Group's corporate structure and the activities being undertaken are identified. Agreements are filed with the Company Secretariat function.

B. System of governance continued

The intragroup agreements that currently exist are between DL Insurance Services Limited (“DLIS”) and UKI, DLIS and CIC, and DLIS and U K Insurance Business Solutions Limited. These have been classified as material intragroup outsource agreements due to the Key Functions and services that are provided by DLIS to the regulated entities. Key Functions and services provided by DLIS include administration, operational support, and managerial advisory services; these are primarily provided from within the UK.

The Group outsources several critical or important activities to various third parties. The Group maintains, manages and provides oversight of these activities in line with the Supplier Management and Outsourcing Minimum Standard. These activities are provided from third parties within the UK, with the exception of a wide range of back office services across claims, customer operations, commercial and finance that are provided from a third party in India and South Africa.

B.8 Any other information

There is no other information.

Section C: **Risk profile** (unaudited)

In this section:

Introduction: Prudent person principle

C.1 Underwriting risk

C.2 Market risk

C.3 Credit risk

C.4 Liquidity risk

C.5 Operational risk

C.6 Other material risks

C.7 Any other information

C. Risk profile

The risk management process outlined in B.3 aims to enable the Group to manage risk in a structured and consistent way and ensure continued effectiveness of the Group's risk mitigation techniques.

Risks are managed on a Group-wide basis for the regulated insurance companies, UKI and CIC and the Group as a whole, as risks faced by the Group, UKI and CIC are similar in nature and scope. References to Group also include the Group regulated insurance companies, UKI and CIC. The Group's risk profile has remained broadly unchanged over the year.

Prudent person principle and management of invested assets

The Prudent person principle defined in Article 132 of the Solvency II Directive includes provisions on how undertakings should invest their assets and is as much a behavioural standard as an assessment of judgements and investment decisions.

Prudence is evidenced in the manner through which investment strategies are developed (with reference to the Group's liabilities and capital), implemented and monitored and the guidance provided by the Investment Committee and Board.

The Investment Management and Treasury ("IMT") function is responsible for ensuring that the Group only invests in assets and instruments where the risks of which can be properly identified, assessed, managed, monitored, controlled and reported in accordance with the Group's ERMF and the Investment Risk Policy. All assets are invested taking into consideration the aggregate security, liquidity, quality and profitability parameters for the investment portfolio as a whole.

Assets are invested in an appropriate manner with the objective of ensuring their nature and duration match technical provisions to mitigate a loss which could arise from the imperfect matching of the timing and size of the cash flows from the investments and those linked to liabilities. The Investment Management Minimum Standard requires the IMT function to perform an asset and liability matching exercise at least annually for each material regulated entity and recommend any changes to asset classes, strategic asset benchmarks or the use of derivatives to improve, inter alia, the matching of cash flows.

The framework ensuring assets are invested in a prudent manner and subject to ongoing monitoring is characterised by the following actions:

- limiting investment in assets not admitted to trading on a regulated financial market;
- carving out investment benchmarks for cash and gilt holdings consistent with the Group's analysis of liquidity requirements in stressed scenarios;
- diversifying exposure to avoid excessive reliance on any particular asset class, issuer, group of companies, industry or geographic area;
- ensuring detailed credit assessments are undertaken prior to investing in any asset or transaction and such assessments are updated at suitable intervals;
- examining credit limits employed to ensure that the size and nature of the limits provided and current utilisations remain appropriate;
- measuring and monitoring risk exposure across the entire portfolio on a daily basis;
- reviewing the performance of all asset classes against market conditions, strategic benchmarks and investment guidelines set;
- reporting market risk measures (in addition to value at risk) to provide regular insights on potential changes to asset prices as a result of market risk; and
- ensuring no uncovered or speculative use of derivatives occurs.

C.1 Underwriting risk

Underwriting risk

This is the risk that future claims experience on business written is materially different from the results expected, resulting in current-year losses. The Group predominantly underwrites personal lines insurance including motor, residential property, roadside assistance, creditor, travel and pet business. The Group also underwrites commercial risks primarily for low-to-medium risk trades within the SME market. Contracts are typically issued on an annual basis which means that the Group's liability usually extends for a 12 month period, after which the Group is entitled to decline to renew or can impose renewal terms by amending the premium or other policy terms and conditions such as the excess as appropriate.

Underwriting risk includes catastrophe risk, the risk of loss, or of adverse change in the value of the insurance liabilities resulting from significant uncertainty of pricing, underwriting and provisioning assumptions related to extreme or exceptional circumstances.

C. Risk profile continued

Reserve risk

Reserve risk is the risk of misstatement of reserves arising from:

- the uncertain nature of claims;
- data issues and changes to the claims reporting process;
- operational failures;
- failure to recognise claims trends in the market; and
- changes in underwriting and business written so that past trends are not necessarily a predictor of the future.

Understatement of reserves may result in not being able to pay claims when they fall due. Alternatively, overstatement of reserves can lead to a surplus of funds being retained resulting in opportunity cost, for example lost investment return or insufficient resource to pursue strategic projects and develop the business.

Risk concentrations

The Group is subject to concentration risk in a variety of forms, including:

- geographic concentration risk – the Group purchases a UK catastrophe reinsurance programme to protect against a modelled one-in-200-year catastrophe loss. The retained deductible is 13.99% of the gross earned premium of the preceding 12 months and at 31 December 2017 was £147 million (2016:£150 million);
- product concentration risk – the Group's business is heavily concentrated in the UK general insurance market. However, the Group offers a diversified portfolio of products and a variety of brands sold through a range of distribution channels to its customers;
- sector concentration risk – the concentration of the Group to any given industry sector is monitored and analysed in respect of commercial customers; and
- reinsurance concentration risk – the Group aims to contract with a diverse range of reinsurers on its contracts to mitigate the credit and / or non-payment risks associated with its reinsurance exposures.

It is important to note that none of these risk categories is independent of the others and that giving due considerations to the relationship between these risks is an important aspect of the effective management of insurance risk.

Management and mitigation

Underwriting risk is controlled through a range of processes:

- underwriting guidelines are set for all transacted business and pricing refined by analysing comprehensive data;
- a range of Key Performance Indicators ("KPIs") tracking underwriting performance are regularly monitored and reported to senior management;
- governance on model change provided by various committees and the internal audits conducted by underwriting;
- catastrophe and motor excess of loss reinsurance limits the Group's exposure to events and large losses; and
- the Group invests in enhanced external data to analyse and mitigate exposures.

Reserve risk is controlled through a range of processes:

- regular reviews of the claims and premiums, along with an assessment of the requirement for a liability adequacy provision for the main classes of business by the internal actuarial team;
- the use of independent actuaries to review periodically the actuarial best estimate reserves produced internally, either through peer review or through provision of independent reserve estimates;
- accompanying all reserve reviews with actuarial assessment of the uncertainties through a variety of techniques including bootstrapping and scenario analysis;
- oversight of the reserving process by relevant senior management and the Board;
- regular reconciliation of the data used in the actuarial reviews against general ledger data and reconciliation of the claims data history against the equivalent data from prior reviews; and
- regular assessment of the uncertainty in the reserves to help the Board set management best estimate reserves.

Note that the underwriting risk and the reserve risk are both mitigated by the reinsurance structure in place.

C. Risk profile continued

Risk sensitivity methods, assumptions, stress testing and sensitivity analysis

Multiple major weather events

Catastrophe events are a material driver of underwriting risk for the Group with reinsurance as an important mitigation. To better understand the Group's exposure in this area, the Group has considered a situation in which the UK faces several weather events over a period of 12 to 18 months, including multiple windstorms, floods, freeze, and subsidence events. Subsidence is not covered by the Group's reinsurance programme. The resulting impact was only slightly higher than the one-year SCR catastrophe risk requirement which was considered reasonable as the combination of such events within 18 months was deemed to be a less frequent occurrence than once in 200 years.

Ogden discount rate and PPOs

The Group's reserves are subject to the risk of retrospective changes in judicial conditions such as the change in the Ogden discount rate announced on 27 February 2017. This is the discount rate set by the Lord Chancellor and used by courts to calculate lump sum awards in bodily injury cases. The rate depends on the final outcome of the Civil Liabilities Bill and has been set at 2.5% since 2001 and changed to minus 0.75% from 20 March 2017.

The Government has now published the draft Civil Liabilities Bill which looks to: support the principle of full compensation; modernise the way the rate is set to reflect the reality of how claimants actually invest; introduce a requirement to review the rate at least every 3 years; and create an independent expert panel to advise the Lord Chancellor in order to help ensure that the rate is set fairly and transparently in future.

Uncertainty in claims reserves estimation is larger for claims such as PPOs for which annually indexed payments are made typically over the lifetime of the injured party. Claims reserves for PPOs are held on a discounted basis and are sensitive to a change in the assumed real discount rate.

Solvency ratio sensitivity analysis

The following table shows the Group's solvency ratio sensitivities to four insurance risk events, estimated based on an assessed impact of scenarios as at 31 December 2017.

The sensitivities have been applied to the Group solvency capital ratio before the inclusion of the dividends announced in February 2018. Other potential risks beyond the ones described could have an additional financial impact on the Group.

Scenario	Impact on solvency capital ratio	
	31 Dec 2017	31 Dec 2016
Motor bodily injury deterioration equivalent to accident years 2008 and 2009	(7pts)	(8pts)
One-off catastrophe loss equivalent to the 1990 storm	(9pts)	(9pts)
One-off catastrophe loss based on extensive flooding of the River Thames	(9pts)	(9pts)
Change in reserving basis for PPOs to use a real discount rate of minus 1% ¹	(13pts)	(13pts)

Note:

1. The methodology for calculating the impact on the ratio of a change in the reserving basis for the PPO's to use a real discount rate of minus 1% has been updated in 2017 and for the comparative period.

C.2 Market risk

This is the risk of loss resulting from fluctuations in the level and in the volatility of market prices of assets, liabilities and financial instruments.

The Group is mainly exposed to the following market risk factors:

- spread risk;
- interest rate risk;
- property risk; and
- foreign currency risk.

Spread risk

This is the risk of loss from the sensitivity of the value of assets and investments to changes in the level or in the volatility of credit spreads over the risk-free interest rate term structure. The level of spread is the difference between the risk-free rate and actual rate paid on the asset, with larger spreads being associated with higher risk assets. The Group is exposed to spread risk through its investments in bonds.

C. Risk profile continued

Interest rate risk

This is the risk of loss from all assets and liabilities for which the net asset value is sensitive to changes in the term structure of interest rates or interest rate volatility. The Group's interest rate risk arises mainly from its debt, floating interest rate investments and assets and liabilities exposed to fixed interest rates.

The subordinated guaranteed dated notes with a nominal value of £500 million were issued on 27 April 2012 at a fixed rate of 9.25%. On the same date, the Group also entered into a 10-year designated hedging instrument to exchange the fixed rate of interest for a floating rate of three-month LIBOR plus a spread of 706 basis points which was credit value adjusted to 707 basis points with effect from 29 July 2013.

On the 8 December 2017, the Group repurchased £250 million nominal value of the subordinated guaranteed dated notes for a purchase price of £330.1 million including accrued interest of £2.7 million and associated transaction costs of £0.6 million.

The remaining notes, with a nominal value of £250 million, have a redemption date of 27 April 2042. The Group has the option to repay the notes on specific dates from 27 April 2022. If the notes are not repaid on that date, the rate of interest will be reset at a rate of the six-month LIBOR plus 7.91%.

On 7 December 2017, the Group issued £350 million of fixed rate perpetual Tier 1 notes with a coupon rate of 4.75% per annum.

The Group also invests in floating rate debt securities, whose investment income is influenced by the movement of the short-term interest rate. A movement of the short-term interest rate will affect the expected return on these investments.

The market value of the Group's financial investments with fixed coupons is affected by the movement of interest rates. For the majority of investments in US Dollar corporate bonds, excluding £403.9 million of short duration high yield bonds (2016: £432.0 million) the Group hedges the exposure of this portfolio to the US Dollar interest rate risk using swaps.

Property risk

This is the risk of loss arising from sensitivity of assets and financial investments to the level or volatility of market prices, rental yields, or occupancy rates of properties. At 31 December 2017, the value of property investments (other than own use) was £313.5 million (2016: £332.8 million). The property investments are located in the UK.

Currency risk

This is the risk of loss from changes in the level or volatility of currency exchange rates.

Exposure to currency risk is generated by the Group's investments in US Dollar and Euro denominated corporate bonds.

The Group maintains exposure to US Dollar securities through £2,084.5 million (2016: £2,107.1 million) of investments in US Dollar corporate bonds and Euro securities through £110.4 million (2016: £91.8 million) of Euro corporate bonds. The foreign currency exposure of these investments is hedged by foreign currency forward contracts, maintaining a minimal unhedged currency exposure on these portfolios, as well as a low basis currency risk on the hedging contracts.

A limited exposure to currency risk also arises through the Group's insurance and other contractual liabilities.

Risk concentrations

Concentration risk arises from inadequately diversified portfolios of assets, in particular:

- large exposures to individual groups;
- large exposures to certain industry sectors;
- large exposures to certain geographies – the Group holds property assets solely within the UK;
- large exposures to exchange rate fluctuations – the Group holds a significant proportion of its assets in US Dollar; and
- large exposures to different groups where movements in values and ratings are closely correlated for any other reason.

The Group manages and controls the concentration risks as part of its market risk mitigation techniques, which are described below.

Management and mitigation

The Group manages and controls the risks in its investment portfolio through:

- strategic asset allocation within the investment portfolio is reviewed by the Investment Committee which makes recommendations to the Board for its investment strategy approval;
- diversification of the types of assets, and tight control of individual credit exposures; and
- risk-reduction techniques, such as hedging foreign currency exposures with forward contracts and hedging exposure to US interest rates with swap contracts.

C. Risk profile continued

The Group's Investment Risk Policy and related minimum standards require the First Line of Defence, in this case the IMT function, to undertake an asset-liability management study at least annually. The study must consider the following:

- mitigation of interest rate risk, typically using key rate duration analysis;
- the implications and rationale for mismatches pursued when backing liabilities on the balance sheet, for example 'real growth' asset strategy supporting inflation linked PPO liabilities;
- suitability and appropriateness of Group asset classes given the risk appetite of the Group and capital position; and
- overall expected returns from the investment portfolio given regulatory capital employed.

The quality of assets held in each segregated portfolio is controlled through investment mandates detailing acceptable credit ratings, issuer concentration limits and prohibited holdings.

The operating framework used by the IMT function, evidenced through the written internal procedures framework and contractual and service level requirements in place with external service providers employed, is designed to ensure:

- assets owned are held securely, with holdings verifiable independently by the Group;
- encumbered assets, for example those allocated as collateral, can be identified easily;
- actual returns received can be measured versus benchmark criteria set and budgeted return assumptions; and
- aggregate and individual asset holdings can be monitored against the key risk controls set; for example, strategic benchmark weightings, credit ratings, issuer exposure limits and credit duration limits.

Risk sensitivity methods, assumptions, and stress testing and sensitivity analysis

The Finance function is responsible for monitoring the regulatory capital requirement to support the investment strategy. To support this, they perform stress tests on the capital, and identify management actions should such stresses occur. Additional stress testing and scenario analysis is carried out by the Risk function. Value at risk is calculated by the Capital Modelling team within the Finance function on a quarterly basis to monitor changes in market conditions on likely capital requirements. Losses may arise from:

- the sensitivity of the value of assets to changes in the level or in the volatility of credit spreads over the risk-free interest rate term structure;
- assets and liabilities for which the net asset value is sensitive to changes in the term structure of interest rates or interest rate volatility;
- the imperfect matching of the timing and size of the cash flows from the investments and those linked to the liabilities; and
- the sensitivity of assets to the level or volatility of market prices of property.

The following table shows the Group's solvency capital ratio sensitivities to two market changes, estimated based on an assessed impact of scenarios as at 31 December 2017.

The sensitivities have been applied to the December 2017 Group solvency capital ratio before the inclusion of the dividends announced in February 2018.

Scenario	Impact on solvency capital ratio	
	31 Dec 2017	31 Dec 2016
100bps increase in credit spreads ^{1,2}	(11 pts)	(10 pts)
100bps decrease in interest rates ²	(9 pts)	(7 pts)

Notes:

1. The methodology for calculating the impact on the ratio of an increase in credit spreads has been updated in 2017 and for the comparative period.
2. The sensitivities only include the assessed impact of the above scenarios in relation to AFS investments.

C.3 Credit risk

This is the risk of loss resulting from default on cash inflows and / or changes in market value of issuers of securities, counterparties and any debtors to which the Group is exposed. The Group is mainly exposed to the following credit risk factors:

- counterparty default risk;
- spread risk (covered under market risk); and
- concentration risk.

C. Risk profile continued

Counterparty default risk

This is the risk of loss from unexpected default of the counterparties and debtors of Group undertakings. This risk is monitored by three forums: the Investment Risk Forum monitors credit spreads as indicators of potential losses on investments incurred but not yet realised; the Credit Risk Forum monitors reinsurance and corporate insurance counterparty default risk; and the NIG credit Committee is responsible for monitoring broker credit risk. The main responsibility of these forums is to ensure that all material aspects of counterparty default risk within the Group are identified, monitored and measured.

The main sources of counterparty default risk for the Group are:

- investments – this arises from the investment of funds in a range of investment vehicles permitted by the investment policy;
- reinsurance recoveries – counterparty exposure to reinsurance counterparties arises in respect of reinsurance claims against which a reinsurance bad debt provision is assessed. PPOs have the potential to increase the ultimate value of a claim and, by their very nature, to significantly increase the length of time to reach final payment. This can increase reinsurance counterparty default risk in terms of both amount and longevity; and
- consumer credit – exposure from offering monthly instalments on annual insurance contracts.

Risk concentrations

Concentration risk arises from inadequately diversified exposure to creditors, in particular:

- large exposures to individual creditors (either bond issuers or deposit-taking institutions); and
- large exposures to different credits where movements in values and ratings are closely correlated.

Management and mitigation

- credit limits are set for each counterparty with an exposure above £10,000 and the Group actively monitors those credit exposures; and
- the Group only purchases reinsurance from reinsurers with at least an A– rating. Certain reinsurance contracts have long durations as a result of bodily injury and PPO claims, and insurance reserves therefore include provisions beyond the levels created for shorter-term reinsurance bad debt. For these contracts, reinsurance is only purchased from reinsurers that hold a credit rating of at least A+ at the time cover is purchased.

Risk sensitivity methods, assumptions, and stress testing and sensitivity analysis

The Finance function monitors the regulatory capital requirement to support the investment strategy employed. They perform stress tests and identify management actions should such stresses occur. One stress test looked at the impact of the Group's largest reinsurer defaulting, which would lead to a financial loss of approximately £200 million, if no recoveries could be made. However, as the default of the Group's largest reinsurer is considered to have a return period of beyond one-in-200 years, this result will not materially impact the capital requirements of the Group.

C.4 Liquidity risk

Liquidity risk is the risk of being unable to realise investments in order to settle financial obligations when they fall due.

Liquidity risk is considered to be immaterial to the SCR for the Group, UKI and CIC.

Management and mitigation

The annual liquidity study must consider access to liquidity in stressed scenarios. The measurement and management of liquidity risk within the Group is undertaken within the limits and other policy parameters of the Group's liquidity risk appetite and is detailed within the liquidity risk minimum standard. At a more granular level, access to liquidity in stressed scenarios is met through holdings of cash, money market funds and sovereign debt securities. The aggregate exposure to illiquid assets is also monitored as part of the aggregate portfolio consideration.

Additional initiatives to support liquidity include sovereign debt security repurchase agreement lines in place. These will enable any short-term material cash requirements that arise which have not been forecast to be covered without unnecessary sales of sovereign debt securities and the associated realised gains or losses on the sale.

The IMT function forms an integral component of the Group's annual strategic plan process and forecast updates during the year. Where AUM are expected to rise or fall materially in the next two years, the IMT function produces proposals for approval by the Investment Committee detailing how liquidity will be managed and maintained, where AUM are falling, or new monies are invested.

C. Risk profile continued

Liquidity risk – expected profit in future premiums

The expected profit in future premiums ("EPIFP") is calculated to assess the impact on own funds of a lapse in certain policies and provides a measure of the insurer's exposure to liquidity risk. It is not a measure of overall profitability of the business, for example it does not allow for all sources of income (e.g. ancillary or investment income); it is calculated on a different expense basis to that of ongoing operating expenses; it does not allow for the development of prior year claims provisions; and it is affected by seasonality of the business written over the year. The amount as at 31 December 2017 for Group and UKI was £99.1 million.

EPIFP figures are calculated, and included in this report, in accordance with the regulatory requirements of Solvency II. EPIFP is not a measure of any element of the profit for the Group and is not to be construed as a profit forecast for the Company or any part of the Group or interpreted to set a floor to the profits of the Company or any part of the Group. In addition, attention is drawn to the 'Forward-looking statements disclaimer' in section F.3 of this document, which applies, without limitation, to the EPIFP.

Risk sensitivity methods, assumptions, and stress testing and sensitivity analysis

The Liquidity Risk Minimum Standard requires the IMT function to maintain short-term cash flow forecasts and maturity ladders to ensure ongoing operational liquidity requirements are met. The function is also required to hold minimum levels of liquidity to meet stressed requirements on an overnight basis, within one month and within three months.

C.5 Operational risk

Operational risk is the risk of loss due to inadequate or failed internal processes, systems, human error or from external events.

Risk concentrations

The Group is subject to concentration in its operational risks through, for example, its IT systems and change programmes; which include the risk of losses in a number of scenarios such as system outages and data security breaches. Technology remains at the heart of the Group operations and focus is on upgrading Group IT systems and capabilities, aimed at improving the digital offering, customer experience and operational efficiency. While progress has been made in each of these three areas, implementation and integration of a range of new IT systems is inherently complex and challenging.

Management and mitigation

The Group is working to improve the performance of its IT systems across the board, while focusing on the development of future systems capability. With significant change underway, the Group is monitoring risks associated with its IT systems' stability, cyber security and the internal control environment.

The Group's risk management framework is designed to enable it to capture and monitor risk information in a robust and consistent way. The performance of outsourced activities is also monitored by the Group.

Risk sensitivity methods, assumptions, and stress testing and sensitivity analysis

The Group's operational risk requirement is calculated by considering a number of scenarios at a 1-in-200 level.

C.6 Other material risks

Reputational risks

Reputational risk is not considered a material risk in its own right within the Group, however, it is considered within the risk drivers and impact of other risk types such as compliance, change, financial reporting, partnership contractual obligations, outsourcing and conduct risks.

Strategic risks

Risks associated with strategic implementation and formulation are considered within the Material Risk Register ("MRR") and monitored by the Executive Committee. Strategic risks are considered to manifest across the MRR and as a result the risk is not explicitly modelled in the Group's partial internal model SCR.

C.7 Any other information

There is no other information.

Section D:

Valuation for solvency purposes

In this section:

- D.1 Assets
- D.2 Technical provisions
- D.3 Other liabilities
- D.4 Alternative methods of valuation
- D.5 Any other information

D. Valuation for solvency purposes

D.1 Assets

Valuation methodology

The Group values all assets, excluding reinsurance receivables, goodwill and intangibles, at fair value on the Group, UKI and CIC Solvency II balance sheets, which represents an amount for which they could be exchanged between knowledgeable willing parties in an arm's length transaction. When fair value is not readily available because the market is not deeply liquid an alternative method of valuation is required. Assets that require the use of an alternative method of valuation are covered in section D.4. Asset recognition and valuation bases have been applied consistently during the reporting period. The assumptions and judgements do not include any assumptions about the future or additional sources of estimation other than those noted. Reinsurance receivables are included in section D.2, Technical provisions.

Group accounting policy – fair value

The accounting policies and the basis of valuation used in the Group IFRS financial statements and individual IFRS financial statements of its subsidiaries are consistently applied, and described in the Group's Annual Report & Accounts 2017 within 'Notes to the consolidated financial statements', note 1 'Accounting policies', which starts on page 117.

Fair value is best demonstrated by reference to a quoted price in an active market. A market is regarded as active if quoted prices are readily and regularly available from an exchange, dealer, broker, industry group, pricing service or regulatory agency, and those prices represent actual and regularly occurring market transactions on an arm's length basis. The appropriate quoted market price for an asset held is usually the current bid price. When current bid prices are unavailable, the price of the most recent transaction provides evidence of the current fair value as long as there has not been a significant change in economic circumstances since the time of the transaction. If conditions have changed since the time of the last transaction, the fair value is determined by reference to observable market data such as prices for similar assets, recent transactions in less active markets or the fair value reflects the change in condition by reference to, but not limited to, interest rates, foreign exchange rates, volatilities in debt prices or credit spreads for similar financial instruments.

If the market for a financial asset is not active, the Group establishes the fair value by using a valuation technique. Valuation techniques include using recent arm's length market transactions between knowledgeable and willing parties (if available), reference to the current fair value of another instrument that is substantially the same, discounted cash flow analysis and option pricing models. If there is a valuation technique commonly used by market participants to price the instrument and that technique has been demonstrated to provide reliable estimates of prices obtained in actual market transactions, the Group uses that technique.

Fair value for derivatives is determined from quoted prices in active markets where available. Where there is no active market for an instrument, fair value is derived from prices for the derivative's components using appropriate pricing or valuation models. Valuation models use inputs for contractual terms and the specific risks inherent in the instrument, market prices, credit curves, yield curves, measure of volatility and correlations of such inputs.

For investment property, fair value is based on current prices using a valuation model that predominantly uses unobservable inputs. Valuations are compared with recent market transactions for similar properties and adjusted for the specific characteristics of each property.

When valuing assets and liabilities in accordance with Solvency II, the fair valuation hierarchy set out below is followed, which is consistent with the fair value measurement hierarchy as applied under IFRS:

Level 1 financial assets are measured in whole or in part by reference to published quotes in an active market. In an active market quoted prices are readily and regularly available from an exchange, dealer, broker, industry group, pricing service or regulatory agency and those prices represent actual and regularly occurring market transactions on an arm's length basis

Level 2 financial assets and liabilities are measured using a valuation technique based on assumptions that are supported by prices from observable current market transactions. These are assets for which pricing is obtained via pricing services, but where prices have been determined in an active market, or financial assets with fair values based on broker quotes or assets that are valued using the Group's own models whereby the majority of assumptions are market observable.

Level 3 fair value measurements used for investment properties, held-to-maturity debt securities, infrastructure debt and commercial real estate loans are those derived from a valuation technique that includes inputs for the asset that are observable.

Key differences between the valuation of assets under Solvency II compared to IFRS

The Group applies a value of zero to goodwill for Solvency II and measures at cost in the IFRS financial statements. For intangible assets other than goodwill, a value of zero is assigned under Solvency II because it is not possible to sell other intangible assets separately or demonstrate that there is a market value for the same or similar assets. In the IFRS financial statements these assets are carried at cost less accumulated amortisation.

Deferred acquisition costs in the Group and UKI financial statements are not recognised as an asset under Solvency II. Insurance and other receivables in the Group and UKI financial statements primarily consist of future cash flows due from policyholders which are not yet due and reflected as an asset within Solvency II technical provisions. Cash flows from policyholders which are due or overdue are reflected as Solvency II receivables.

D. Valuation for solvency purposes continued

The table below and those on pages 45 and 46 summarise the Group's, UKI's and CIC's Solvency II balance sheet in column (d) and compares the assets and liabilities as reported in the respective IFRS financial statements in column (a). Reclassifications required to align the respective IFRS financial statements to the prescribed format of the Solvency II balance sheet QRT's are given in column (b).

Group Balance Sheet – IFRS and SII

As at December 2017 (£m)	Notes to the financial statements	IFRS (a)	Reclassifications (b)	IFRS reclassified (c) = (a) + (b)	SFCR note	Solvency II (d)	Valuation difference (e) = (d - c)
Assets							
Goodwill	17	212.3	—	212.3		—	(212.3)
Other intangible assets		258.8	—	258.8		—	(258.8)
Deferred acquisition costs	22	185.4	—	185.4		—	(185.4)
Deferred tax assets		—	—	—	D.1.10	41.9	41.9
Pension benefit surplus	25	14.4	—	14.4	D.1.14	14.4	—
Property plant & equipment (own use)	18	174.4	—	174.4	D.1.7	58.7	(115.7)
Property (other than own use)	19,28	313.5	—	313.5	D.1.1	313.5	—
Financial investments		4,639.4	1,100.6	5,740.0		5,743.5	3.5
Government bonds ¹	26	268.7	(9.5)	259.2	D.1.2	259.2	—
Corporate bonds ¹	26	4,259.1	36.7	4,295.8	D.1.3	4,299.3	3.5
Collateralised securities ¹	26	27.2	(27.2)	—		—	—
Collective investments undertakings ²	27	—	1,100.6	1,100.6	D.1.4	1,100.6	—
Derivatives	24	84.4	—	84.4	D.1.5	84.4	—
Loans and mortgages	26	485.4	—	485.4	D.1.6	494.9	9.5
Reinsurance recoverables ³	21	1,178.5	(18.6)	1,159.9		1,136.1	(23.8)
Receivables		1,106.4	(862.2)	244.2		243.0	(1.2)
Insurance and intermediaries ⁵	23	949.6	(858.0)	91.6	D.1.8	91.6	—
Reinsurance receivables ³	23	26.3	(4.2)	22.1	D.1.8	22.1	—
Trade, not insurance		130.5	—	130.5	D.1.8	129.3	(1.2)
Cash and cash equivalents ²	27	1,358.6	(1,100.6)	258.0	D.1.9	258.0	—
Other assets		21.1	34.2	55.3		59.1	3.8
Own shares ⁴		—	34.2	34.2		38.0	3.8
Other assets		21.1	—	21.1	D.1.11	21.1	—
Total assets		9,948.2	(846.6)	9,101.6		8,363.1	(738.5)
Liabilities							
Technical provisions ⁵	33,34	5,826.0	(541.8)	5,284.2	D.2	5,205.8	(78.4)
Other provisions	36	74.2	—	74.2	D.3.1	74.2	—
Deferred tax liabilities	13	31.1	—	31.1	D.3.2	—	(31.1)
Derivatives	24	12.0	—	12.0	D.1.5	12.0	—
Debts owed to credit institutions	27	54.1	—	54.1	D.3.4	54.1	—
Insurance & intermediaries payables ⁵	36	115.3	(105.2)	10.1	D.3.5	10.1	—
Reinsurance payables ³	36	74.3	(22.8)	51.5	D.3.5	51.5	—
Payables (trade, not insurance) ^{5,6}	13,36	434.9	(206.8)	228.1		228.1	—
Subordinated liabilities ⁶	32	264.7	(4.2)	260.5	D.3.6	264.8	4.3
Total liabilities		6,886.6	(880.8)	6,005.8		5,900.6	(105.2)
Excess of assets over liabilities⁴		3,061.6	34.2	3,095.8		2,462.5	(633.3)

Notes for reclassifications in column (b):

1. Reclassification of £36.7 million to corporate bonds from collateralised securities (£27.2 million) and Government bonds (£9.5 million) as at 31 December 2017.
2. Reclassification of £1,100.6 million from cash and cash equivalents to collective investments undertakings as at 31 December 2017.
3. Reclassification into reinsurance recoverables of £18.6 million from reinsurance payables of £(22.8) million and insurance receivables of £4.2 million as at 31 December 2017.
4. Own shares held at 31 December 2017 of £34.2 million are held within equity on the IFRS balance sheet have been reclassified from excess of assets over liabilities to own shares.
5. Reclassification of £858.0 million insurance and intermediaries receivables, £(105.2) million of insurance and intermediaries payables and £(211.0) million of trade payables into technical provisions as at 31 December 2017.
6. Reclassification of accrued interest of £4.2 million from subordinated liabilities to trade payables as at 31 December 2017.

D. Valuation for solvency purposes continued

UKI Balance Sheet – IFRS and SII

As at December 2017 (£m)	Notes to the financial statements	IFRS (a)	Reclassifications (b)	IFRS reclassified (c) = (a) + (b)	SFCR note	Solvency II (d)	Valuation difference (e) = (d - c)
Assets							
Other intangible assets	14	4.7	—	4.7		—	(4.7)
Deferred acquisition costs	18	186.5	—	186.5		—	(186.5)
Deferred tax assets		—	—	—		—	—
Participations	16	11.5	—	11.5		13.4	1.9
Property (other than own use)	15	303.9	—	303.9	D.1.1	303.9	—
Financial Investments		4,633.2	877.3	5,510.5		5,513.9	3.4
Government bonds ¹	21	263.4	(9.5)	253.9	D.1.2	253.9	—
Corporate bonds ¹	21	4,259.2	36.7	4,295.9	D.1.3	4,299.3	3.4
Collateralised securities ¹	21	27.2	(27.2)	—		—	—
Collective investments undertakings ²	22	—	877.3	877.3	D.1.4	877.3	—
Derivatives	20	83.4	—	83.4	D.1.5	83.4	—
Loans and mortgages	21	485.4	—	485.4	D.1.6	494.9	9.5
Reinsurance recoverables ³	17	1,162.6	(18.5)	1,144.1		1,120.2	(23.9)
Receivables		1,030.2	(862.2)	168.0		168.0	—
Insurance and intermediaries ⁴	19	950.1	(858.0)	92.1	D.1.8	92.1	—
Reinsurance receivables ³	19	25.8	(4.2)	21.6	D.1.8	21.6	—
Trade, not insurance		54.3	—	54.3	D.1.8	54.3	—
Cash and cash equivalents ²	22	1,122.4	(877.3)	245.1	D.1.9	245.1	—
Total assets		8,940.4	(880.7)	8,059.7		7,859.4	(200.3)
Liabilities							
Technical provisions ⁴	26,27	5,804.6	(541.8)	5,262.8	D.2	5,185.1	(77.7)
Other provisions	28	31.7	—	31.7	D.3.1	31.7	—
Deferred tax liabilities	12	34.4	—	34.4	D.3.2	13.2	(21.2)
Derivatives	20	12.0	—	12.0	D.1.5	12.0	—
Debts owed to credit institutions	22	48.6	—	48.6	D.3.4	48.6	—
Financial liabilities other than debt owed to credit institutions	28	134.6	—	134.6		134.6	—
Insurance & intermediaries payables ⁴	28	117.5	(105.2)	12.3	D.3.5	12.3	—
Reinsurance payables ³	28	74.2	(22.7)	51.5	D.3.5	51.5	—
Payables (trade, not insurance) ^{4,5}	12,28	311.7	(202.6)	109.1		109.1	—
Subordinated liabilities ⁵	25	520.4	(8.4)	512.0	D.3.6	529.6	17.6
Total liabilities		7,089.7	(880.7)	6,209.0		6,127.7	(81.3)
Excess of assets over liabilities		1,850.7	—	1,850.7		1,731.7	(119.0)

Notes for reclassifications in column (b):

1. Reclassification of £36.7 million to corporate bonds from collateralised securities (£27.2 million) and Government bonds (£9.5 million) as at 31 December 2017.
2. Reclassification of £877.3 million from cash and cash equivalents to collective investments undertakings as at 31 December 2017.
3. Reclassification into reinsurance recoverables of £18.5 million from reinsurance payables of £(22.7) million and reinsurance receivables of £4.2 million as at 31 December 2017.
4. Reclassification of £858.0 million of insurance and intermediaries receivables, £(105.2) million of insurance and intermediaries payables and £(211.0) million of trade payables into technical provisions as at 31 December 2017.
5. Reclassification of accrued interest of £8.4 million from subordinated liabilities to trade payables as at 31 December 2017.

D. Valuation for solvency purposes continued

CIC Balance Sheet – IFRS and SII

As at December 2017 (£m)	Notes to the financial statements	IFRS (a)	Reclassifications (b)	IFRS Reclassified (c) = (a) + (b)	SFCR note	Solvency II (d)	Valuation difference (e) = (d – c)
Assets							
Collective investments undertakings ¹	10	–	17.7	17.7	D.1.4	17.7	–
Reinsurance recoverables	12	29.1	–	29.1		28.8	(0.3)
Reinsurance receivables	9	0.5	–	0.5		0.5	–
Trade, not insurance		0.5	–	0.5		0.5	–
Cash and cash equivalents ¹	10	17.7	(17.7)	–	D.1.9	–	–
Total assets		47.8	–	47.8		47.5	(0.3)
Liabilities							
Technical provisions	12	34.5	–	34.5	D.2	33.5	(1.0)
Deferred tax liabilities	7	–	–	–		0.1	0.1
Financial liabilities other than debt owed to credit institutions	13	0.2	–	0.2		0.2	–
Payables (trade, not insurance)		0.3	–	0.3		0.4	0.1
Total liabilities		35.0	–	35.0		34.2	(0.8)
Excess of assets over liabilities		12.8	–	12.8		13.3	0.5

Note for reclassifications in column (b):

1. Reclassification of £17.7 million from cash and cash equivalents to collective investments undertakings as at 31 December 2017.

D.1.1 Investment property (other than for own use)

Property is stated at fair value in the Solvency II balance sheets and IFRS financial statements based on valuations by independent registered valuers, using consistent assumptions and methodology (see also D.4). Properties classified as assets held for sale in the IFRS financial statements are valued on the same basis for Solvency II and included within properties (other than for own use) in the Group balance sheet.

D.1.2 Government bonds

Government bonds are valued at fair value in the Solvency II balance sheets and IFRS financial statements. These are based primarily in whole or in part by reference to published quotes in an active market; the value for Group is £215.3 million and £210.1 million for UKI. The Group has £43.9 million and UKI £43.9 million of government bonds that are measured using a valuation technique based on assumptions that are supported by prices from observable current market transactions.

D.1.3 Corporate bonds

Corporate bonds in the Solvency II balance sheets are held at fair value. In the IFRS financial statements for Group and UKI they are also held at fair value with the exception of a small portfolio with a value of £103.6 million (fair value: £107.2 million) classified as held to maturity under IFRS, and held at amortised cost. The fair value for Solvency II is calculated using valuation techniques that are based on observable current market transactions and model inputs for recent transactions or observable market data.

D.1.4 Collective investment undertakings

Collective investment schemes are measured at fair value in the Solvency II balance sheets and the IFRS financial statements. They consist primarily of money market funds and are valued by reference to published quotes in an active market.

D.1.5 Derivatives

Derivatives are carried at fair value in both the Solvency II balance sheets and IFRS financial statements, using the valuation technique described on page 43.

D.1.6 Loans

Under IFRS loans are valued at amortised cost, The Solvency II fair value is derived using a valuation based on a risk-adjusted discounted cash flow model. When determining the risk-adjusted discount rate, inputs for the relevant base rate, average trading spread of the overall market or sector and the credit risk specific to the loan are used.

D.1.7 Property, plant and equipment held for own use

In the Solvency II balance sheets, property is valued at fair value, based on valuations provided by independent registered valuers using assumptions and methodology that are consistent with investment property. Plant and equipment is valued at fair value only if an external market exists and a price verified by an independent valuer can be obtained, which results in many smaller items being valued at zero. The IFRS financial statements value property, plant and equipment at historic cost less depreciation.

D. Valuation for solvency purposes continued

D.1.8 Insurance and other receivables

Insurance and other receivables are valued at fair value in the Solvency II balance sheets and the IFRS financial statements. Fair value is derived from discounting expected future cash flows by a risk-adjusted discount rate. Where the time value of associated cash flows is not significant, cash flows are not discounted.

D.1.9 Cash and cash equivalents

Cash and cash equivalents are valued at fair value in the Solvency II balance sheets and the IFRS financial statements. They comprise cash in hand and on demand deposits with banks, and short-term highly liquid investments that are readily convertible to known amounts of cash and subject to insignificant risk of change in value.

D.1.10 Deferred tax assets

Deferred tax assets arise solely in the Group Solvency II balance sheet and are valued at fair value.

D.1.11 Other assets

Other assets on the Solvency II balance sheets are valued at fair value.

D.1.12 Investment in subsidiaries

In the Solvency II balance sheet of UKI, its subsidiary CIC is valued using an adjusted equity method that applies Articles 75 to 86 of the Solvency II Directive. The investment in subsidiary is included within other assets.

D.1.13 Leasing arrangements

The Group does not have any finance leases. For details of operating lease commitments, please refer to section A.4.

D.1.14 Retirement benefit obligation

The Group operated a small defined benefit pension scheme with a balance sheet asset value of £14.4 million as at 31 December 2017, which was closed in 2003. The scheme assets and liabilities are measured at fair value. More detail can be found in the Group's Annual Report & Accounts 2017 in note 25 'Retirement benefit obligations' which starts on page 151.

D.2 Technical provisions

The Group estimates the technical provisions using a range of actuarial and statistical techniques. Projections of ultimate claims cost involve assumptions across a range of variables, including estimates of trends in claims frequency and average claim amounts.

This is largely consistent with the valuation of net reserves for IFRS reporting; however, there are a few material differences in the valuation of technical provisions, see 'Differences in valuation methodologies' on page 48.

Simplified methods used to calculate the technical provisions

The technical provisions are calculated as the sum of a net actuarial best estimate ("ABE") plus a risk margin. The best estimate is comprised of a claims provisions component and a premium provisions component.

The risk margin is calculated at an entity level and allocated to lines of business.

Group – net technical provisions

As at 31 December 2017	Net best estimates £m	Risk margin £m	Total net technical provisions £m
Non-life lines of business			
Motor vehicle liability insurance	2,338.4	125.2	2,463.6
Other motor insurance	137.9	6.2	144.1
Fire and other damage to property insurance	532.8	42.6	575.4
General liability insurance	315.7	17.0	332.7
Other non-life lines of business	155.8	5.5	161.3
	3,480.6	196.5	3,677.1
Life lines of business			
Annuities from non-life	285.4	107.1	392.5
Total lines of business	3,766.0	303.6	4,069.6

D. Valuation for solvency purposes continued

UKI – net technical provisions

As at 31 December 2017	Net best estimates £m	Risk margin £m	Total net technical provisions £m
Non-life lines of business			
Motor vehicle liability insurance	2,337.2	124.9	2,462.1
Other motor insurance	137.9	6.2	144.1
Fire and other damage to property insurance	532.8	42.6	575.4
General liability insurance	315.7	17.0	332.7
Other non-life lines of business	155.8	5.5	161.3
	3,479.4	196.2	3,675.6
Life lines of business			
Annuities from non-life	282.4	106.9	389.3
Total lines of business	3,761.8	303.1	4,064.9

CIC – net technical provisions

As at 31 December 2017	Net best estimates £m	Risk margin £m	Total net technical provisions £m
Non-life lines of business			
Motor vehicle liability insurance	1.2	0.3	1.5
	1.2	0.3	1.5
Life lines of business			
Annuities from non-life	3.0	0.2	3.2
Total lines of business	4.2	0.5	4.7

Uncertainty associated with technical provisions

Insurance is inherently uncertain with respect to the amount and timing of future cash flows, requiring the use of judgement in estimating these cash flows. Reserving risk is a significant risk to the Group and consists predominantly of bodily injury claims from the Motor business. Some of the factors that are considered when assessing the level of technical provisions include the class of business, timeliness of notification of claims, validity of claims made against a policy and validity of the amount of the claim. At any time there is a range of possible outcomes at which the technical provisions could ultimately settle and, as time passes, the uncertainty surrounding likely claims settlement for past accident periods reduces. The uncertainty is greater for bodily injury claims due to the time it takes for these claims to settle. This is particularly true for PPOs awarded to settle some of the large bodily injury claims, in which annually indexed payments are made over the lifetime of the injured party.

Future management actions are allowed for in future reinsurance premium expenses. Reinsurance in place for the Group is considered to be renewed on similar terms (unless expected to be materially different) where premium exposure continues beyond the term of current treaties.

Uncertainty with respect to policyholder behaviour is considered within the calculations for bound but not incepted business. Policy data information for new and renewal business is considered by product and business category.

Differences in valuation methodologies

For each line of business, the differences in the valuation of claims provisions best estimates from IFRS reporting to a Solvency II basis break down into a number of discrete adjustments to the net IFRS insurance liabilities comprising claims reserves and other technical provisions. The net IFRS insurance liabilities include unearned premium reserve net of deferred acquisition costs and reinsurance assets per the IFRS financial statements. These differ in materiality depending on the nature of the cash flows associated with each line of business.

D. Valuation for solvency purposes continued

For the claims provisions, differences to IFRS are as follows:

- allowances for events not in data are a requirement for Solvency II purposes whereas these are not treated in the same way under IFRS. The events not in data allowance is calculated using market standard techniques;
- explicit allowances are made for additional expenses other than claims handling, such as investment management expenses on the earned claims reserves and profit share payments due on partnership arrangements;
- all cash flows are discounted for Solvency II purposes using the risk-free yield curve provided by European Insurance and Occupational Pensions Authority with volatility adjustment as appropriate. This represents a change to IFRS reporting where only PPO claims are discounted; and
- cash flows for PPO claims are projected using inflation assumptions relative to the prescribed risk-free discount rates for Solvency II, before volatility adjustment.

Group

As at 31 December 2017	IFRS net insurance liabilities £m	Solvency II adjustments £m	Solvency II net technical provisions £m
Non-life lines of business			
Motor vehicle liability insurance	2,688.6	(225.0)	2,463.6
Other motor insurance	258.6	(114.4)	144.2
Fire and other damage to property insurance	756.2	(180.8)	575.4
General liability insurance	332.5	0.2	332.7
Other non-life lines of business	165.2	(4.0)	161.2
	4,201.1	(524.0)	3,677.1
Life lines of business			
Annuities from non-life ¹	261.0	131.5	392.5
Total	4,462.1	(392.5)	4,069.6

UKI

As at 31 December 2017	IFRS net insurance liabilities £m	Solvency II adjustments £m	Solvency II net technical provisions £m
Non-life lines of business			
Motor vehicle liability insurance	2,686.8	(224.7)	2,462.1
Other motor insurance	258.6	(114.5)	144.1
Fire and other damage to property insurance	755.1	(179.7)	575.4
General liability insurance	332.5	0.2	332.7
Other non-life lines of business	165.1	(3.8)	161.3
	4,198.1	(522.5)	3,675.6
Life lines of business			
Annuities from non-life ¹	257.4	131.9	389.3
Total	4,455.5	(390.6)	4,064.9

CIC

As at 31 December 2017	IFRS net insurance liabilities £m	Solvency II adjustments £m	Solvency II net technical provisions £m
Non-life lines of business			
Motor vehicle liability insurance	1.8	(0.3)	1.5
Life lines of business			
Annuities from non-life ¹	3.6	(0.4)	3.2
Total	5.4	(0.7)	4.7

Note:

¹ The IFRS net insurance liabilities above for annuities from nonlife are different from the net approved PPO claims provision in the corresponding IFRS financial statements, which excludes an allocation of reinsurance bad debt but does include both lump sum payments and annuities.

D. Valuation for solvency purposes continued

In addition, there are further differences between IFRS and Solvency II reporting bases that apply to all lines of business:

- the calculation of premium provisions to allow for all future cash flows relating to unearned obligations under Solvency II replaces the concept of holding a provision for unearned premium, deferred acquisition costs and liability adequacy reserve, if required; and
- an industry-wide prescribed method for calculating risk margin above the best estimate technical provisions under Solvency II is applied as opposed to a margin setting process governed internally within the Group. The risk margin is calibrated once a year to ensure the approach adopted is aligned to the derivation of the SCR.

Differences in the valuation between UKI and CIC

Within the Group's Solvency II technical provisions, the valuation for risk margin differs for UKI and CIC. The risk margin for UKI is taken from the Internal Model whilst the risk margin for CIC is based on a standard formula calculation. No additional diversification is allowed for between the entities in the Group level risk margin.

Volatility adjustment

The volatility-adjusted risk-free discount rate is used to discount reserve cash flows for the motor liability, general liability and non-life annuity classes of business. This includes application to reserves held for PPO claims. The part of the discounting credit relating to the volatility adjustment amount net of reinsurance £26.2 million, £26.1 million and £0.2 million in the respective balance sheets of the Group, UKI and CIC at 31 December 2017.

Recoverables from reinsurance contracts and special purpose vehicles

The Group has a range of reinsurance protection types which include property catastrophe, motor risk excess of loss, commercial property risk excess of loss, commercial liability risk excess of loss and smaller programmes to protect against travel, subsidence and creditor claims. Facultative cover has been purchased on selected commercial risks, mainly property. Motor risk excess of loss in past years has predominantly been on a risk attaching basis.

The Group allows for future reinsurance expenditure as an increase to the technical provisions on a contractually bound basis.

There are currently no special purpose vehicles in place for the Group's reinsurance.

Changes in assumptions relating to the calculation of technical provisions

The real discount rate assumption for projecting PPO claim cash flows has been changed to allow for higher rates of inflation. There have been no other key changes in assumptions relating to the calculation of technical provisions since last year.

The following represent parameter updates made to the calculation of technical provisions over the same period. For these parameter updates, the underwriting methodology remains unchanged.

- the claims ABE, allowance for expenses, allowance for reinsurer counterparty default and cash flow patterns are updated throughout the year for all lines of business to allow for IFRS reserve movements and changes in the data underlying all assumptions;
- for the premium provisions, balance sheet items, claims assumptions and expense assumptions are updated through the year; and
- the events not in data model has been updated for the latest volatility parameters and scenarios.

D.3 Other liabilities

Valuation methodology

The Group values all liabilities at the amount for which they could be transferred, or settled, between knowledgeable willing parties in an arm's length transaction. In the Group, UKI and CIC Solvency II balance sheets, no adjustments are made for own credit risk, except for subordinated liabilities. There have been no changes to the bases used for recognition, valuation and estimation of other liabilities during the reporting period. The assumptions and judgements do not include any assumptions about the future or additional sources of estimation other than those noted.

The tables in D.1 summarise and compare the value of Group, UKI and CIC Solvency II liabilities with those contained in the Group, UKI and CIC IFRS financial statements.

D.3.1 Provisions other than technical provisions

Provisions other than technical provisions are valued in the Solvency II balance sheets and the IFRS financial statements at fair value. Fair value is derived from discounting expected future cash flows by a risk-adjusted discount rate. Where the time value of associated cash flows is not significant, cash flows are not discounted.

D.3.2 Deferred tax liabilities

Deferred tax liabilities arise in the UKI Solvency II and IFRS balance sheet and the CIC Solvency II balance sheet. All deferred tax liabilities are valued at fair value.

D. Valuation for solvency purposes continued

D.3.3 Derivatives

Derivatives are carried at fair value in the Solvency II balance sheets and IFRS financial statements using the valuation technique described in section D.1.5.

D.3.4 Debts owed to credit institutions

Debts owed to credit institutions comprise bank overdrafts and are measured at amortised cost using the effective interest rate method in the IFRS financial statements. Given the very short-term nature of these balances this is also considered to be a reasonable approximation to fair value for the Solvency II balance sheet.

D.3.5 Insurance and other payables

Insurance and other payables are valued at fair value in the Solvency II balance sheets and the IFRS financial statements. Fair value is derived from discounting expected future payments by a risk-adjusted discount rate. Where the time value of associated payments is not significant, cash flows are not discounted.

D.3.6 Subordinated liabilities

The Group has subordinated guaranteed dated notes in the Solvency II balance sheets held at a fair value which is determined by reference to quoted prices in an active market. In the IFRS financial statements they are valued at amortised cost plus a fair value hedge adjustment for a 10-year hedge to exchange the fixed rate of interest for a floating rate of three-month LIBOR plus a spread of 707 basis points. The valuation in the Solvency II balance sheets is at fair value, based on quoted market price less the movement in own credit risk since initial recognition.

D.4 Alternative methods of valuation

The majority of the assets and other liabilities included in the Balance Sheet QRT's of the Group, UKI and CIC in sections G.2, G.3 and G.4 respectively are based on quoted market information or observable active market data. Where the quoted market information or observable market data is not available, an alternative method for valuation is used.

The Solvency II valuation methodology hierarchy is different from the IFRS fair value hierarchy but the methodology for valuing assets and other liabilities at fair value are consistent. The assets and other liabilities that are not valued by references to published quotes in an active market and would be classified as Level 2 or 3 in the Group's IFRS fair value hierarchy are classified as alternative methods of valuation under Solvency II. The Group only uses alternative valuation methods when a readily observable, external market valuation is not available, or where the relevant market is deemed to be inactive.

Estimation and uncertainty of alternative method of valuation

Alternative methods for valuation include the use of estimates and assumptions that are not market observable but based on independent third-party evidence and internally developed models. Valuation uncertainty arises from variation in the expected range of the key inputs into the models, judgements relating to model inputs, and reliance on third party valuation standards. Where an alternative valuation method is used the variation to fair value is immaterial.

The material assets and other liabilities, disclosed in the Balance Sheet QRTs in sections G.2, G.3 and G.4, that have alternative methods of valuation methods applies are as follows:

Investment property and property for own use

Property is stated at fair value in the Solvency II balance sheets based on valuations by independent registered valuers. Fair value is based on current prices for similar properties adjusted for the specific characteristics of each property including the size, location and condition by reference to the benchmark property transactions.

Participations (UKI only)

Participations of £13.3 million are valued using an adjusted equity method, which takes a share of the excess of assets over liabilities of the CIC subsidiary. This method is used because a quoted market price from an active market in the equity of the subsidiary is not available.

Government and corporate bonds

If the market for a financial asset is not active, the Group establishes the fair value by using a valuation technique. Valuation techniques include using recent arm's length market transactions between knowledgeable and willing parties (if available), reference to the current fair value of another instrument that is substantially the same, discounted cash flow analysis and option pricing models. If there is a valuation technique commonly used by market participants to price the instrument and that technique has been demonstrated to provide reliable estimates of prices obtained in actual market transactions, the Group uses that technique.

Loans and mortgages

The Solvency II fair value is derived using a valuation based on a risk-adjusted discounted cash flow model. When determining the risk-adjusted discount rate, inputs for the relevant base rate, average trading spread of the overall market or sector and the credit risk specific to the loan are used.

D. Valuation for solvency purposes continued

Derivative asset and liabilities

Fair value for derivatives is determined from quoted prices in active markets where available. Where there is no active market for an instrument, fair value is derived from prices for the derivative's components using appropriate pricing or valuation models. Valuation models use inputs for contractual terms and the specific risks inherent in the instrument, market prices, credit curves, yield curves, measure of volatility and correlations of such inputs.

Subordinated liabilities

The valuation in the Solvency II balance sheet is at fair value based on reference to quoted market price less the movement in own credit risk since initial recognition. The discounted cash flow uses a discount rate that takes into account the specific characteristics of the subordinated debt adjusted for market conditions. An adjustment is made to the calculated fair value to remove the movement in the Group's own credit risk since initial recognition.

D.5 Any other information

There is no other information.

Section E:

Capital management

In this section:

- E.1 Own funds
- E.2 Solvency capital requirement and minimum capital requirement (unaudited)
- E.3 Use of the duration-based equity risk sub-module in the calculation of the solvency capital requirement
- E.4 Use of the internal model (unaudited)
- E.5 Non-compliance with the minimum capital requirement and non-compliance with the solvency capital requirement
- E.6 Any other information

E. Capital management

E.1 Own funds

E.1.1 Objective, policies and processes for managing own funds

The Group aims to manage its capital efficiently and generate long-term sustainable value for shareholders, while balancing operational, regulatory, rating agency and policyholder requirements.

The Group aims to grow its regular dividend in line with business growth.

Where the Board believes that the Group has capital which is expected to be surplus to the Group's requirements for a prolonged period, it would intend to return any surplus to shareholders. In normal circumstances, the Board expects that a solvency capital ratio around the middle of its risk appetite range of 140% to 180% of the Group's SCR would be appropriate and it will therefore take this into account when considering the potential for special dividends. For UKI and CIC, their individual boards have approved a minimum threshold of 125% of their respective SCRs.

In the normal course of events the Board will consider whether or not it is appropriate to distribute any surplus capital to shareholders once a year, alongside the full year results.

The Group expects that one-third of the annual dividend will generally be paid in the third quarter as an interim dividend, and two-thirds will be paid as a final dividend in the second quarter of the following year. The Board may revise the dividend policy from time to time. The Company may consider a special dividend and / or a repurchase of its own shares to distribute surplus capital to shareholders.

The Group seeks to maintain sufficient economic capital consistent with its strategic aim of maintaining a credit rating in the 'A' range.

The policies and processes that the Group adopts to manage its own funds to mitigate the risk of breaching regulatory and internal capital adequacy are described in the Group's Capital Management Minimum Standard, which includes the following key controls:

Capital forecasting

The Group's five-year strategic plan includes a capital plan that forecasts the SCR and coverage ratios for the Group, UKI and CIC.

Adverse capital movement

A regular review of the capital adequacy of each Group undertaking is undertaken to ensure no deterioration below SCR or agreed risk appetite ranges, including review of the forecast capital position and the quality of capital within own funds.

Management of dividend governance

Dividends paid by all Group undertakings are considered and approved by the responsible board. The Company, UKI and CIC all have the right to cancel (or defer) their own dividend payments or other distributions after declaration if the undertakings cease to hold capital resources equal to or in excess of their SCR.

There have been no material changes to the objectives, policies and processes for managing own funds over the reporting period.

E. Capital management continued

Movement in Group own funds during 2017 (millions)

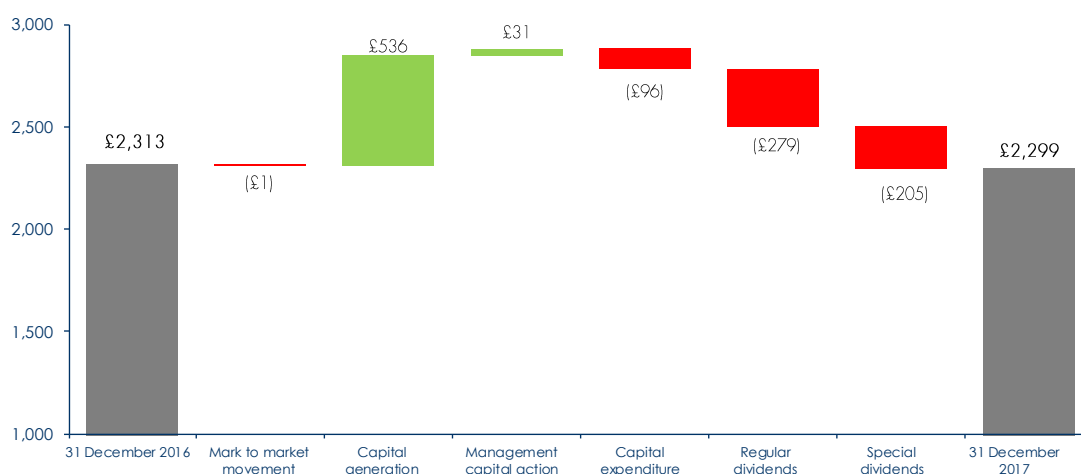

Note:

Mark to market movements represent movements in IFRS AFS revaluation reserve, fair value adjustments on financial investments held at amortised cost under IFRS and fair value adjustments on property held for own use.

E.1.2 Analysis of the components of own funds

The following table lists total own-fund items by tier for the Group, UKI and CIC.

As at 31 December 2017	Group £m	UKI £m	CIC £m
Ordinary share capital	150.0	580.8	–
Reconciliation reserve	1,495.4	850.9	13.3
Tier 1 unrestricted own funds	1,645.4	1,431.7	13.3
Tier 1: restricted Tier 1 debt	346.5	–	–
Total Tier 1 own funds	1,991.9	1,431.7	–
Tier 2: subordinated liabilities	264.8	529.6	–
Tier 3: deferred tax assets	41.9	–	–
Total own funds	2,298.6	1,961.3	13.3

As at 31 December 2016	Group £m	UKI £m	CIC £m
Ordinary share capital	150.0	580.8	–
Reconciliation reserve	1,590.4	913.1	13.1
Total Tier 1 own funds	1,740.4	1,493.9	13.1
Tier 2: subordinated liabilities	537.5	537.5	–
Tier 3: deferred tax assets	35.4	–	–
Total own funds	2,313.3	2,031.4	13.1

Note:

The difference between own funds for the Group and the total of UKI and CIC relates to own funds of non-regulated entities.

Group

Tier 1 own funds comprise Ordinary Share capital of £150.0 million (2016: £150.0 million) and the reconciliation reserve of £1,495.4 million (2016: £1,590.4 million). The reconciliation reserve consists of Solvency II excess of assets over liabilities of £2,462.5 million (2016: £1,945.1 million) less the value of own shares held of £38.0 million (2016: £36.8 million) and the foreseeable dividend of £390.7 million (2016: £132.5 million) and other basic own fund items consisting of Tier 3 deferred tax assets of £41.9 million (2016: £35.4 million), Ordinary Share capital of £150.0 million (2016: £150.0 million) and Tier 1 notes of £346.5m (2016: £nil).

Tier 1 own funds after foreseeable dividends represents 87% of own funds and 143% of the SCR.

E. Capital management continued

On 7 December 2017, the Group issued £350.0 million of Tier 1 notes with a coupon of 4.75%. The notes have an optional redemption date of 7 December 2027 and if the notes are not repaid on that date, the rate of interest will be reset. The notes are direct, unsecured and subordinated obligations of the issuer ranking pari passu and without any preference amongst themselves. The Group has the option to cancel the coupon payment which becomes mandatory upon breach or non-compliance with the Group SCR, a breach of Minimum Capital Requirement ("MCR") or where the Group has insufficient distributable reserves. Proceeds of this issuance have primarily been used to fund the repurchase of £250 million subordinated guaranteed dated notes which had a market value of £326.8 million.

The Group has issued Tier 1 notes to mitigate the risk of a single refinancing date. In addition, under the Solvency II eligibility restrictions the Group previously had limited options to raise additional subordinated debt (Tier 2) capital to recover solvency. As a result of raising the Tier 1 notes and repaying half of the Tier 2 capital the Group has ability to raise further Tier 2 capital should this be required.

Tier 2 own funds comprise subordinated guaranteed dated notes which were issued on 27 April 2012 at a fixed rate of 9.25%. On the same date, the Group also entered into a 10-year designated hedging instrument to exchange the fixed rate of interest for a floating rate of three-month LIBOR plus a spread of 706 basis points which was credit value adjusted to 707 basis points with effect from 29 July 2013.

The notes, with a nominal value of £250 million, have a redemption date of 27 April 2042. The Group has the option to repay the notes on specific dates from 27 April 2022. If the notes are not repaid on that date, the rate of interest will be reset at a rate of the six-month LIBOR plus 7.91%. The notes are unsecured, subordinated obligations of the Group, and rank pari passu without any preference among themselves. In the event of a winding-up or of bankruptcy, they are to be repaid only after the claims of all senior creditors have been met. The Group has the option to defer interest payments in certain circumstances on the notes but to date has not exercised this right.

UKI

Tier 1 own funds comprise Ordinary Share capital of £580.8 million (2016: £580.8 million) and the reconciliation reserve of £850.9 million (2016: £913.1 million). The reconciliation reserve consists of Solvency II excess of assets over liabilities of £1,731.7 million (2016: £1,493.9 million) less the value of the foreseeable dividend of £300.0 million (2016: £nil) and Ordinary Share capital of £580.8 million (2016: £580.8 million).

Tier 2 own funds comprise the UKI subordinated guaranteed dated notes which were issued on 27 April 2012 at a fixed rate of 9.5%. On the same date, the Company also entered into a 10-year hedge to exchange the fixed rate of interest for a floating rate of three-month LIBOR plus a spread of 706 basis points which was credit value adjusted to 707 basis points with effect from 29 July 2013.

The nominal £500 million notes have a redemption date of 27 April 2042. The Company has the option to repay the notes on specific dates from 27 April 2022. If the notes are not repaid on that date, the rate of interest will be reset at a rate of six-month LIBOR plus 8.16%. The notes are unsecured, subordinated obligations of the Company, and rank pari passu without any preference among themselves. In the event of a winding-up or of bankruptcy, they are to be repaid only after the claims of all senior creditors have been met. The Company has the option to defer interest payments in certain circumstances on the notes but to date has not exercised this right.

During the period there were no significant changes in tier 2 own funds.

CIC

Tier 1 own funds comprise Ordinary Share capital of £100 (2016: £100) and the reconciliation reserve. The reconciliation reserve consists of Solvency II excess of assets over liabilities of £13.3 million (2016: £13.1 million) less ordinary share capital of £100 (2016: £100).

Eligible own funds by tier to cover the solvency capital requirement and minimum capital requirement

Group

The Group's SCR as at 31 December 2017 was £1,392.7 million; the limit that the sum of tier 2 and tier 3 capital shall not exceed 50% of the SCR is a restriction on available own funds to meet the SCR and was not applicable to the Group at 31 December 2017. Total eligible own funds to meet the SCR were £2,298.6 million, consisting of tier 1 - unrestricted of £1,645.4 million, tier 1 - restricted of £346.5 million, tier 2 of £264.8 million and tier 3 of £41.9 million. The restriction that tier 1 - restricted own funds should not exceed 20% of total tier 1 own funds when satisfying the requirement that eligible tier 1 items shall be at least 50% of the SCR is not applicable to the Group.

The Group's MCR as at 31 December 2017 was £601.7 million; tier 3 own funds are not eligible to cover the MCR. The limit that tier 2 own funds shall not exceed 20% of the MCR is the only other restriction of eligible own funds to meet the MCR. The total eligible own funds to meet the MCR was £2,112.2 million, consisting of unrestricted tier 1 of £1,645.4 million, restricted tier 1 of £346.5 million and restricted tier 2 of £120.3 million. The restriction that tier 1 - restricted own funds should not exceed 20% of total tier 1 own funds when satisfying the requirement that eligible tier 1 items shall be at least 80% of the MCR is not applicable to the Group.

E. Capital management continued

UKI

There were no restrictions on UKI's own funds to meet its SCR as at 31 December 2017 of £1,361.5 million.

The UKI MCR as at 31 December 2017 was £598.4 million; the restriction that limits tier 2 items to 20% of the MCR is the only restriction. Total eligible own funds to meet the MCR were £1,551.4 million, consisting of unrestricted tier 1 of £1,431.7 million and restricted tier 2 of £119.7 million.

CIC

As at 31 December 2017, the CIC SCR was £1.7 million and the MCR was £3.3 million. There are no quantitative eligibility limits applicable to tiers 1, 2 or 3.

Reconciliation of Group equity in the IFRS financial statements to Solvency II own funds as at 31 December 2017 (millions)

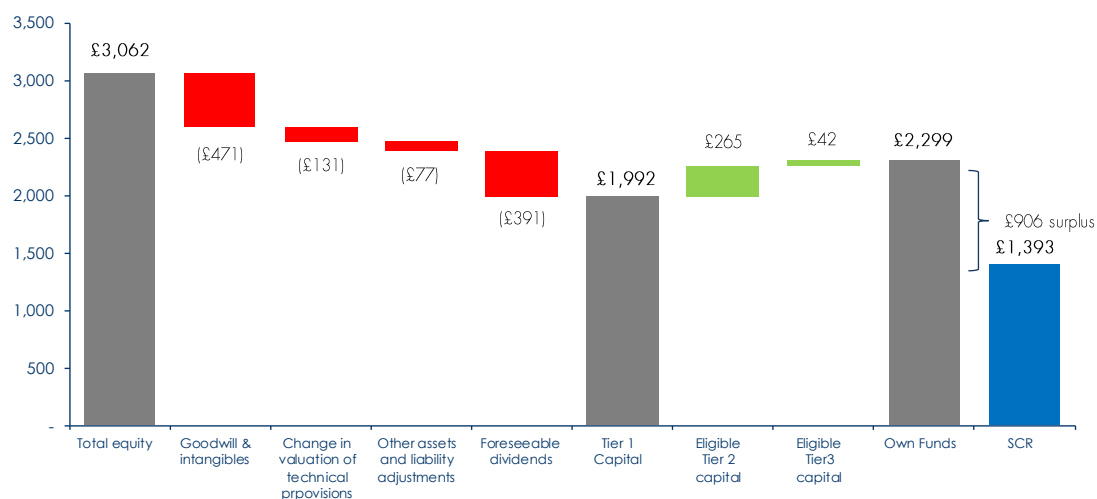

Note:

Changes in valuation of technical provisions: In its 2017 Preliminary Results, the Group included Solvency II valuation adjustments based on estimates. These estimates have been subsequently updated and final numbers are included above. This has improved the capital coverage ratio previously reported of 162% to 165%.

Reconciliation of UKI equity in the IFRS financial statements to Solvency II own funds as at 31 December 2017 (millions)

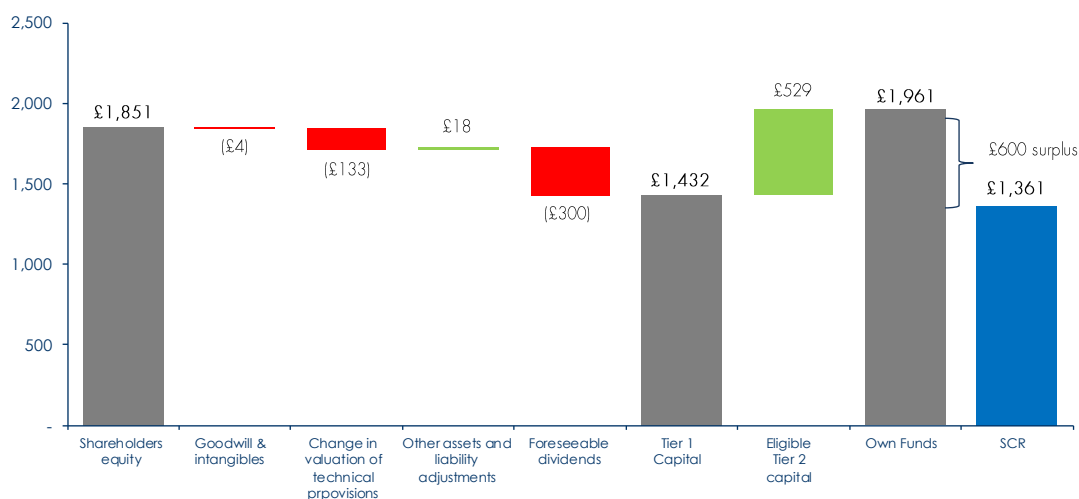

E. Capital management continued

Reconciliation of IFRS equity and Solvency II excess of assets over liabilities

As at 31 December 2017	Group £m	UKI £m	CIC £m
Total equity	3,061.6	1,850.7	12.8
Goodwill and intangible assets	(471.1)	(4.7)	–
Change in valuation of technical provisions	(130.8)	(132.7)	0.6
Other asset and liability adjustments	(77.1)	18.4	(0.1)
Foreseeable dividends	(390.7)	(300.0)	–
Excess of assets over liabilities (Tier 1)	1,991.9	1,431.7	13.3

Neither UKI nor CIC have any items deducted from own funds or any restrictions that would affect the availability and transferability of own funds within the undertakings.

At the Group level there are no anticipated restrictions on the fungibility of own funds within Group entities and no items of own funds are dedicated to absorb specific losses. There are no restrictions on the transferability of own funds between Group entities.

E.2. Solvency capital requirement and minimum capital requirement (unaudited)

Solvency capital requirement and minimum capital requirement at the end of the reporting period

Group partial internal model solvency capital requirement

As at 31 December	2017 £m	2016 £m
SCR for the Group companies excluding UKI and its subsidiary (CIC), using integration technique 1	31.2	25.3
SCR for UKI using the IECM	1,361.5	1,377.9
Consolidated Group SCR	1,392.7	1,403.2

The Group received PRA approval to use a PIM for the calculation of its Group and solo SCRs from 1 July 2016. The SCR is not subject to supervisory assessment.

The integration technique to be used to integrate the PIM into the SCR standard formula is integration technique 1 as set out in Annex XVIII of the Commission Delegated Regulation (EU) 2015/35.

The undertakings included in the scope of the model for the calculation of the Group SCR are:

- Direct Line Insurance Group plc
- U K Insurance Limited
- Churchill Insurance Company Limited
- The internal model is approved to calculate the solo SCR for UKI.

The notional standard formula of the Group holding company, excluding UKI, is calculated partly on a consolidated basis and partly on the basis of a standard formula equity risk shock for strategic participations in respect of certain entities.

The Group SCR is calculated by adding together the SCR for UKI calculated using the IECM (A) and a standard formula SCR for the non-UKI companies in the Group (B1). This standard formula SCR uses a consolidated balance sheet approach, except for certain entities (B2) which are treated as equity investments of the Group. The diagram on page 59 illustrates the generic approach.

E. Capital management continued

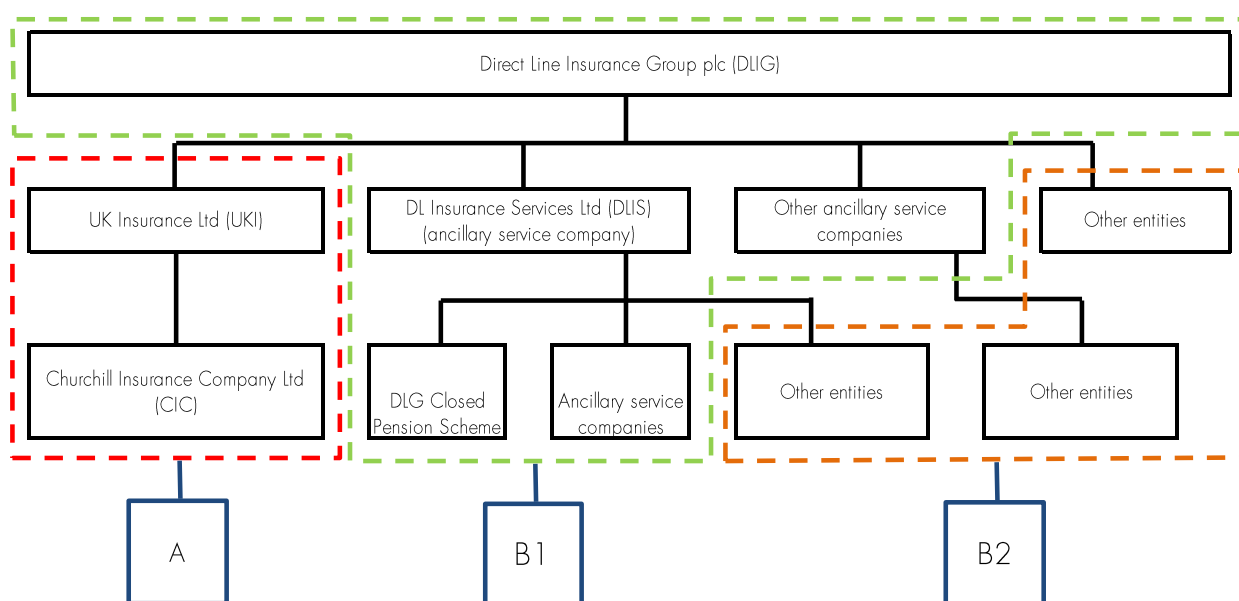

The solo SCR for UKI includes all risks arising from CIC due to UKI owning 100% of CIC. The solo SCR for CIC is calculated using the standard formula.

The calculation of the solo SCR for CIC and for DLIG (excluding UKI) using the standard formula uses the parameters as referred to in the Solvency II regulations. The Group did not apply for undertaking specific parameters as referred to in Chapter V – Section 12 to be used. Simplified calculations as referred to in Subsection 6 of the Solvency II Delegated Regulation 2015/35 are not used.

There are no significant restrictions to the fungibility and transferability of own funds eligible for covering the Group SCR.

Due to the integration technique adopted, there are no diversification benefits taken between UKI and the Group entities. There are diversification benefits assumed between the Group entities in group B as far as has been allowed for by the standard formula. The contribution of risk from CIC to UKI is based on a CIC standard formula calculation, excluding any inter-company reinsurance provided to CIC from UKI. An uplift is applied to the CIC insurance risk calculation to reflect the limitations of the standard formula in dealing with the risks arising from PPOs.

The IECM approach used to calculate the solo SCR for UKI is the same as used to calculate the contribution of UKI to the Group SCR.

Summary of entity solvency capital requirements and minimum capital requirements

As at 31 December	SCR 2017 £m	MCR 2017 £m
Direct Line Insurance Group plc	1,392.7	601.7
U K Insurance Limited	1,361.5	598.4
Churchill Insurance Company Limited	1.7	3.3

E. Capital management continued

Group solvency capital requirement – further information

As at 31 December	Group PIM 2017 £m	Group PIM 2016 £m
Non-Life underwriting risk	–	–
Life underwriting risk	–	–
Health underwriting risk	–	–
Market risk	24.4	22.0
Counterparty default risk	14.4	8.1
Total – undiversified risk	38.8	30.1
Diversification	(7.6)	(4.8)
Basic SCR	31.2	25.3
Operational risk	–	–
Loss absorbing capacity of deferred taxes	–	–
Other adjustments	–	–
UKI SCR	1,361.5	1,377.9
Group SCR	1,392.7	1,403.2

Material changes over the year

Changes in the Group SCR are driven from changes in the UKI SCR which are discussed below. In respect of the element of the Group SCR attributed to the holding company, the increase is due to changes in the investment portfolio and increase in the inter-company loan position with UKI.

Group minimum capital requirement – further information

There have been no material movements in the Group MCR, which has increased from £596.7 million to £601.7 million over the reporting period.

UKI solo solvency capital requirement – further information

As at 31 December	IECM 2017 £m	IECM 2016 £m
IECM – insurance risk	1,181.5	1,127.3
IECM – market risk	653.6	692.7
IECM – credit risk	64.9	65.4
IECM – operational risk	265.8	306.3
IECM – risk margin volatility	42.1	42.7
IECM total – undiversified	2,207.9	2,234.4
IECM diversification	(751.5)	(795.5)
IECM diversified total	1,456.4	1,438.9
Loss absorbing capacity of deferred taxes	(94.9)	(61.0)
UKI SCR	1,361.5	1,377.9

Material changes over the year

The higher insurance risk is due to increases in Motor and Commercial exposure and an update to the Solvency II technical provisions at the year end. This is partly offset by lower reserves relating to large bodily injury claims and the cessation of the Nationwide partnership.

Market risk has decreased primarily due to the tightening of credit spreads over the year.

The decrease in operational risk reflects a reduction in change risk and information security risk following improvements in the control environment. These are partially offset by consideration of the risks associated with the incoming EU General Data Protection legislation.

The increase in the loss absorbing capacity of deferred taxes is due to increased profits in 2017 compared to 2016, increasing the potential for tax carry-back.

E. Capital management continued

In addition, approval was received from the PRA in October 2017 for a major model change, triggered through an accumulation of minor changes. The aggregate impact of these changes since the initial approval of the IECM was approximately (4%).

UKI minimum capital requirement – further information

There have been no material movements in the UKI MCR, which has increased from £593.5 million to £598.4 million over the reporting period.

CIC solo solvency capital requirement – further information

As at 31 December	Standard formula 2017 £m	Standard formula 2016 £m
Non-Life underwriting risk	0.3	0.7
Life underwriting risk	0.1	0.1
Health underwriting risk	–	–
Market risk	0.6	0.5
Counterparty default risk	0.9	0.9
Total – undiversified risk	1.9	2.2
Diversification	(0.5)	(0.6)
Basic SCR	1.4	1.6
Operational risk	0.3	0.5
CIC SCR	1.7	2.1

Material changes over the year

There have been no material changes to the CIC SCR over the reporting period.

CIC minimum capital requirement – further information

There have been no material movements in the CIC MCR, which has increased from £3.2 million to £3.3 million over the reporting period.

Simplified calculation in the standard formula

No material simplifications have been used to derive the SCR using the standard formula.

E.3 Use of the duration-based equity risk sub-module in the calculation of the solvency capital requirement (unaudited)

The duration-based equity risk sub-module is not used in the calculation of the SCR for the Group, UKI or CIC.

E.4 Use of the internal model (unaudited)

Capital management

The IECM's primary use is to calculate the SCR. The IECM is used to assess the impact of capital management decisions and is an input into the strategic planning process as an input into the ORSA to support dividend planning and budgeting.

Risk management

The IECM is used to quantify risks on the MRR and is also used to highlight the key risks to the Group. Furthermore, the IECM supports the risk appetite setting process and the review of financial forecasts, by providing stressed scenarios to give the Group's Executive management a range of possible outcomes.

Reinsurance management

Through the modelling of the base and alternative reinsurance structures, the IECM supports catastrophe and motor reinsurance management, by assessing the impact on profitability and capital requirements.

Portfolio management

The IECM is used to understand the relative riskiness of different cohorts of the business and is used to advise on capital allocation to business categories. New initiatives and opportunities involve the IECM to indicate on the impact on the SCR and associated return on equity.

E. Capital management continued

Investment management

The IECM is used to assess the risk associated with the current asset mix, the impact of changes to the SCR and asset risk of changes in proposed asset portfolios and as a feed into the analysis of liquidity requirements which in turn impact the strategic investment decisions.

Scope of the internal model

The PIM calculates the Group SCR by adding together the SCR for UKI calculated using the IECM, and a standard formula SCR for the non-UKI companies in the Group. This standard formula uses a consolidated balance sheet approach, except for certain entities which are treated as equity investments of the Group. See the diagram on page 59 which illustrates this approach.

The internal model is approved to calculate the solo SCR for UKI.

The notional standard formula for the Group companies (Section E.2), excluding UKI and its subsidiary CIC, is calculated partly on a consolidated basis and partly on the basis of a standard formula equity risk shock for strategic participations in respect of certain entities. The underlying assets and liabilities of entities in group B1 are consolidated before applying the standard formula calculation. This sub-group consists of the Group holding company, ancillary service companies and the Group's closed pension scheme. The latter is not an entity within the Group, but exposes it to pension scheme risk through its sponsor DLIS.

The risks included in the notional standard formula of the Group companies (excluding UKI and its subsidiary) are predominantly market risk and counterparty credit risk. Market risk arises from the assets held at Group level and those held by the associated Group pension scheme. Counterparty credit risk arises mainly from debtor balances and cash holdings.

The scope of the IECM is defined in terms of legal entities and risk categories that are represented in the IECM SCR. The IECM is considered a full internal model for the calculation of the solo UKI SCR as it includes all quantifiable material risks.

The following legal entities are included in the IECM SCR:

- U K Insurance Limited
- Churchill Insurance Company Limited

All other legal entities within the Group are excluded from the scope of the IECM.

The following risk types are included in the scope of the IECM:

- underwriting risk;
- reserving risk;
- catastrophe risk;
- market risk;
- credit risk;
- liquidity risk; and
- operational risk.

The following risk types are not within the scope of the IECM, being regarded as non-quantifiable risks:

- strategic risk;
- reputational risk; and
- regulatory risk.

The IECM includes an allowance for the loss absorbing capacity for deferred taxes due to the potential for tax carry back. Risks arising due to PPOs are assessed in underwriting risk and reserving risk. Market risk includes the assessment of interest rate risk arising from assets and liabilities. Liquidity risk is considered in the IECM but is assessed at zero due to the amount of liquid assets held.

Methods used to calculate the probability distribution forecast and the solvency capital requirement

Internal Economic Capital Management overview

The IECM is a full internal model as outlined by Article 112 of the Solvency II Directive. The calculation kernel within the IECM is Direct Line Insurance Internal Capital Engine ("DIICE").

DIICE uses stochastic processes and Monte-Carlo simulation methods to investigate the uncertainty in real world financial quantities over time by modelling real world processes as predictable movements onto which a random element is added. This random element represents the level of uncertainty within the process being modelled. Risk is measured by simulating several thousand random outcomes and observing the distribution of the outputs.

E. Capital management continued

DIICE produces future financial statements as well as a breakdown of the impact on the balance sheet by risk type. This enables the Group to understand the potential real world impact of a scenario and allows for integration into the risk management system of the Group. DIICE simulates many possible closing balance sheets and provides a range of possible outcomes from which probabilistic measures can be obtained. This method allows the SCR to be set by measuring the 99.5th value-at-risk of the movement in own funds over a one-year period.

DIICE is structured around a series of dependent modelling components. Each component models a specific aspect of an insurance company's operations, for example claims payments or reinsurance recoveries, and may depend on previous components, for example claims depend on a claims inflation component. The components with DIICE may contribute to one or more of the risk types being assessed.

Internal Economic Capital Management structure

All financial modelling is a simplification of the real world. Within DIICE this is partly addressed by grouping potential risks into homogenous cohorts rather than modelling each policy, claim or risk individually. The balance between aggregation and individual detail is important and will vary depending on the materiality and complexity of the risk being modelled.

The business structure in DIICE reflects the way in which the business is organised operationally and is split across the following categories: Motor; Home; Rescue and Other Personal Lines; Commercial and Run Off. Within each category there are classes where the risks are different, for example Home is split into Own Brands and partnerships due to profit sharing arrangements and Commercial is analysed by risk type (Motor, Property and Liability) and channel (Direct and Broker). This allows for the model output to be useful and it also makes it more straightforward to source appropriate data.

The biggest risk that the Group faces is uncertainty regarding claims. Within each category, claims are modelled by loss types reflecting the different risks and influences on each type of claims. For example, Motor claims are modelled as attritional third-party property damage, attritional third-party bodily injury (capped), attritional other, large, PPO and catastrophe claims. The modelling of detailed loss types reflects the materiality, risk characteristics and homogeneity of the underlying risks being considered.

Difference between standard formula and internal model used

There are significant differences in both model structure and parameters when comparing the standard formula and the internal model. The IECM has been designed to model business processes whereas the standard formula focuses purely on a silo approach to considering specific risks with an aggregation methodology overlaid on top. The IECM is primarily calibrated to UKI data and uses expert judgement from the business, whereas the standard formula is calibrated using industry-based data and expert judgements.

There are significant differences between the IECM and standard formula SCR methodologies. The most significant differences are outlined below:

Profit

The IECM allows for expected profit over the year. The standard formula does not and this can be a significant difference.

Diversification

The correlations within the IECM SCR have been based on UKI data and expert judgement from the business. The standard formula SCR uses correlations that have been calibrated to industry-based data and expert judgement. The correlation parameters between risk types in the IECM are lower than for the standard formula. In particular the relationship between insurance risk and market risk is assumed to be lower in the IECM than that assumed in the standard formula.

Market risk

The major difference relates to the use of an economic scenario generator ("ESG") by the IECM to assess market risk. The assumptions made within the ESG differ from those made by the standard formula, which primarily considers shocks in specific market variables and then attempts to apply a dependency structure on top. The ESG considers the related evolution of economic variables over the year, considers movements in cash flows and changes in the balance sheet in a year's time. This results in differences in the Interest Rate Risk, Property Risk and Spread Risk SCRs between the IECM and the standard formula.

E. Capital management continued

Non-life underwriting risk

The IECM assumes a lower level of one-year reserve volatility than that prescribed by the standard formula. The IECM SCR also considers the variability of the premium provision as at one year after the valuation date. The standard formula SCR does not consider the risk associated with this provision. All of UKI's insurance business is included within the non-life underwriting risk module of the IECM. The standard formula non-life underwriting risk calculation excludes the annuity portion of approved PPO claims, which are considered within the life underwriting risk component, as well as the income protection business, which is considered within the health underwriting risk component. This further reduces the diversification effect within non-life underwriting risk in the standard formula compared with the IECM. This diversification effect is however allowed for in the standard formula when aggregating the various underwriting risk components. The IECM allows for PPOs explicitly including longevity, wage inflation, propensity and reinsurance indexation. The IECM SCR utilises specialist catastrophe modelling software and focuses on those catastrophe types that have affected UKI in the past or that are most likely given the UKI portfolio. The standard formula SCR is based on prescribed scenarios which are in turn based on the SII lines of business written by UKI.

Risk margin volatility

The IECM SCR includes allowance for risk margin volatility.

Operational risk

The IECM SCR basis uses a scenario-based approach which represents the UKI risk profile, taking into account its current risk and control environment. The standard formula calculates the SCR for operational risk, based on the premium earned in the last 12 months, the Solvency II technical provisions at the valuation date and the change in earned premium when compared to the 12 months prior to the last 12 months.

Tax

The UKI standard formula takes credit for any deferred tax liability which exists in UKI, however this is not allowed for in the IECM SCR.

Future Ogden discount risk

There is no allowance for future Ogden discount rate change in the UKI standard formula. The IECM SCR includes an amount for future Ogden discount rate risk.

CIC

The method used to calculate the IECM capital charge for the risk relating to CIC is to use an uplifted standard formula calculation, with no diversification benefit applied for the rest of UKI, whereas the standard formula approach is to apply an equity risk shock reflecting UKI's shareholding in CIC allowing for some diversification with other risks.

Risk measure and period used in the internal model

The Group's PIM uses a confidence level of 99.5% over a one-year period and therefore provides an equivalent level of protection for policyholders.

Nature and appropriateness of the data used in the Internal Economic Capital Model

The IECM uses both internal data and external data in order to calibrate parameters. Key internal data is primarily comprised of claims data which is also used for reserving and pricing purposes. The data is directly related to the risks on the balance sheet and those expected to be assumed in the next 12 months of underwriting and therefore appropriate to use for the calibration of the IECM following adjustments for changes in exposure and risk mix.

Where there is insufficient internal data the IECM relies on external models and data. The key risks which utilise external models and data are catastrophe risk and market risk. External models and data are subject to the same standards as internally developed models.

Market studies and industry data are used as a reference and as validation points. In particular the Institute and Faculty of Actuaries PPO working party results are considered.

E.5 Non-compliance with the minimum capital requirement and non-compliance with the solvency capital requirement

The Group is compliant with the MCR and SCR.

E.6 Any other information

There is no other additional information to report.

Section F:

Other information

In this section:

- F.1 Approval by the Boards
- F.2 Report of the external independent Auditor
- F.3 Forward-looking statements disclaimer
- F.4 Glossary

F. Other information

F.1 Approval by the Boards of the Single Solvency and Financial Condition Report for the year ended 31 December 2017

We certify that:

- the Single Solvency and Financial Condition Report has been properly prepared in all material respects in accordance with the PRA rules and Solvency II Regulations; and

We are satisfied that:

- throughout the financial year in question, the insurer has complied in all material respects with the requirements of the PRA rules and Solvency II Regulations as applicable to the insurer; and
- it is reasonable to believe that, at the date of the publication of the Single Solvency and Financial Condition Report, the insurer has continued so to comply, and will continue so to comply in the future.

On behalf of the Boards

Penny James

Chief Financial Officer

1 May 2018

F. Other information continued

F.2 Report of the external independent Auditor to the Directors of Direct Line Insurance Group plc, U K Insurance Limited and Churchill Insurance Company Limited (together "the Group"), pursuant to Rule 4.1 (2) of the External Audit Chapter of the PRA Rulebook applicable to Solvency II firms

Report on the Audit of the relevant elements of the Single Group Solvency and Financial Condition Report

Opinion

Except as stated below, we have audited the following documents prepared by the company as at 31 December 2017:

- the 'Valuation for solvency purposes' and 'Capital Management' sections of the Single Group Solvency and Financial Condition Report of the Group as at 31 December 2017, ('the Narrative Disclosures subject to audit'); and
- Direct Line Insurance Group plc templates S.02.01.02 S.22.01.22, S.23.01.22 and S.32.01.22
- U K Insurance Limited templates S.02.01.02, S.12.01.02, S.17.01.02, S.22.01.21, S.23.01.01 and S.28.01.01
- Churchill Insurance Company Limited templates S.02.01.02, S.12.01.02, S.17.01.02, S.22.01.21, S.23.01.01, S.25.01.21 and S.28.01.01

Together ('the Templates subject to audit').

The Narrative Disclosures subject to audit and the Templates subject to audit are collectively referred to as the '**relevant elements of the Single Group Solvency and Financial Condition Report**'.

We are not required to audit, nor have we audited, and as a consequence do not express an opinion on the Other Information which comprises:

- information contained within the relevant elements of the Single Group Solvency and Financial Condition Report set out above which are or derive from the internal / partial internal model Solvency Capital Requirement, as identified in the Appendix to this report;
- the 'Executive summary', 'Business and performance', 'System of governance' and 'Risk profile' elements of the Single Group Solvency and Financial Condition Report;
- Direct Line Insurance Group plc templates S.05.01.02, S.05.02.01, S.25.02.22 and S.25.03.22;
- U K Insurance Limited templates S.05.02.01, S.05.01.02, S.19.01.21 and S.25.03.21;
- Churchill Insurance Company Limited templates S.05.02.01, S.05.01.02 and S.19.01.21;
- the written acknowledgement by management of their responsibilities, including for the preparation of the Single Group Solvency and Financial Condition Report ('**the Responsibility Statement**'); and
- information which pertains to an undertaking that is not a Solvency II undertaking and has been prepared in accordance with PRA rules other than those implementing the Solvency II Directive or in accordance with an EU instrument other than the Solvency II regulations ('**the sectoral information**').

To the extent the information subject to audit in the relevant elements of the Single Group Solvency and Financial Condition Report includes amounts that are totals, sub-totals or calculations derived from the Other Information, we have relied without verification on the Other Information.

In our opinion, the information subject to audit in the relevant elements of the Single Group Solvency and Financial Condition Report of the Group as at 31 December 2017 is prepared, in all material respects, in accordance with the financial reporting provisions of the PRA Rules and Solvency II regulations on which they are based, as modified by relevant supervisory modifications, and as supplemented by supervisory approvals and determinations.

Basis for opinion

We conducted our audit in accordance with International Standards on Auditing (UK) (ISAs (UK) including ISA (UK) 800 and ISA (UK) 805. Our responsibilities under those standards are further described in the *Auditor's Responsibilities for the Audit of the relevant elements of the Single Group Solvency and Financial Condition Report* section of our report. We are independent of the Group in accordance with the ethical requirements that are relevant to our audit of the Single Group Solvency and Financial Condition Report in the UK, including the FRC's Ethical Standard as applied to public interest entities, and we have fulfilled our other ethical responsibilities in accordance with these requirements. We believe that the audit evidence we have obtained is sufficient and appropriate to provide a basis for our opinion.

F. Other information continued

Emphasis of Matter – Basis of Accounting

We draw attention to the 'Valuation for solvency purposes', 'Capital management' and other relevant disclosures sections of the Single Group Solvency and Financial Condition Report, which describe the basis of accounting. The Single Group Solvency and Financial Condition Report is prepared in compliance with the financial reporting provisions of the PRA Rules and Solvency II regulations, and therefore in accordance with a special purpose financial reporting framework. The Single Group Solvency and Financial Condition Report is required to be published, and intended users include but are not limited to the PRA. As a result, the Single Group Solvency and Financial Condition Report may not be suitable for another purpose. Our opinion is not modified in respect of these matters.

Conclusions relating to going concern

We are required by ISAs (UK) to report in respect of the following matters where:

- the Directors' use of the going concern basis of accounting in the preparation of the Single Group Solvency and Financial Condition Report is not appropriate; or
- the Directors have not disclosed in the Single Group Solvency and Financial Condition Report any identified material uncertainties that may cast significant doubt about the Company's ability to continue to adopt the going concern basis of accounting for a period of at least twelve months from the date when the Single Group Solvency and Financial Condition Report authorised for issue.

We have nothing to report in relation to these matters.

Other Information

The Directors are responsible for the Other Information.

Our opinion on the relevant elements of the Single Group Solvency and Financial Condition Report does not cover the Other Information and, we do not express an audit opinion or any form of assurance conclusion thereon.

In connection with our audit of the Single Group Solvency and Financial Condition Report, our responsibility is to read the Other Information and, in doing so, consider whether the Other Information is materially inconsistent with the relevant elements of the Single Group Solvency and Financial Condition Report, or our knowledge obtained in the audit, or otherwise appears to be materially misstated. If we identify such material inconsistencies or apparent material misstatements, we are required to determine whether there is a material misstatement in the relevant elements of the Single Group Solvency and Financial Condition Report or a material misstatement of the Other Information. If, based on the work we have performed, we conclude that there is a material misstatement of this Other Information, we are required to report that fact.

We have nothing to report in relation to these matters.

Responsibilities of Directors for the Single Group Solvency and Financial Condition Report

The Directors are responsible for the preparation of the Single Group Solvency and Financial Condition Report in accordance with the financial reporting provisions of the PRA rules and Solvency II regulations.

The Directors are also responsible for such internal control as they determine is necessary to enable the preparation of a Single Group Solvency and Financial Condition Report that is free from material misstatement, whether due to fraud or error.

Auditor's Responsibilities for the Audit of the relevant elements of the Single Group Solvency and Financial Condition Report

It is our responsibility to form an independent opinion as to whether the relevant elements of the Single Group Solvency and Financial Condition Report are prepared, in all material respects, with financial reporting provisions of the PRA Rules and Solvency II regulations on which they are based.

Our objectives are to obtain reasonable assurance about whether the relevant elements of the Single Group Solvency and Financial Condition Report are free from material misstatement, whether due to fraud or error, and to issue an auditor's report that includes our opinion. Reasonable assurance is a high level of assurance, but it is not a guarantee that an audit conducted in accordance with ISAs (UK) will always detect a material misstatement when it exists. Misstatements can arise from fraud or error and are considered material if, individually or in the aggregate, they could reasonably be expected to influence the decision making or the judgement of the users taken on the basis of the Single Group Solvency and Financial Condition Report.

A further description of our responsibilities for the audit of the financial statements is located on the Financial Reporting Council's website at <https://www.frc.org.uk/auditorsresponsibilities>

The same responsibilities apply to the audit of the Single Group Solvency and Financial Condition Report.

F. Other information continued

Use of our Report

This report is made solely to the Directors of Direct Line Insurance Group plc, U K Insurance Limited and Churchill Insurance Company Limited in accordance with Rule 4.1 (2) of the External Audit Chapter of the PRA Rulebook for Solvency II firms. We acknowledge that our report will be provided to the PRA for the use of the PRA solely for the purposes set down by statute and the PRA's rules. Our audit work has been undertaken so that we might state to the insurer's Directors those matters we are required to state to them in an auditor's report on the relevant elements of the Single Group Solvency and Financial Condition Report and for no other purpose. To the fullest extent permitted by law, we do not accept or assume responsibility to anyone other than the Company and the PRA, for our audit work, for this report or for the opinions we have formed.

Other Matter

The Group has authority to calculate its Group Solvency Capital Requirement using a partial internal model ("**the Model**"), and U K Insurance using an internal model ("**the Model**") approved by the Prudential Regulation Authority in accordance with the Solvency II Regulations. In forming our opinion (and in accordance with PRA Rules), we are not required to audit the inputs to, design of, operating effectiveness of and outputs from the Model, or whether the Model is being applied in accordance with the Company's application or approval order.

Report on Other Legal and Regulatory Requirements

In accordance with Rule 4.1 (3) of the External Audit Chapter of the PRA Rulebook for Solvency II firms we are required to consider whether the Other Information is materially inconsistent with our knowledge obtained in the audit of Direct Line Insurance Group plc's statutory financial statements. If, based on the work we have performed, we conclude that there is a material misstatement of this other information we are required to report that fact.

We have nothing to report in relation to this matter.

Adam Addis (Statutory Auditor)
For and on behalf of Deloitte LLP
Statutory Auditor
London, United Kingdom
1 May 2018

F. Other information continued

Appendix – relevant elements of the Solvency and Financial Condition Report that are not subject to audit

Direct Line Insurance Group plc (Group partial internal model)

The relevant elements of the Group SFCR that are not subject to audit comprise:

- The following elements of Group template S.02.01.02:
 - Row R0550: Technical provisions – non-life (excluding health) – risk margin
 - Row R0590: Technical provisions – health (similar to non-life) – risk margin
 - Row R0640: Technical provisions – health (similar to life) – risk margin
 - Row R0680: Technical provisions – life (excluding health and index-linked and unit-linked) – risk margin
 - Row R0720: Technical provisions – Index-linked and unit-linked – risk margin
- The following elements of Group template S.22.01.22:
 - Column C0030: Impact of transitional measure on technical provisions
 - Row R0010: Technical provisions
 - Row R0090: Solvency Capital Requirement
- The following elements of Group template S.23.01.22:
 - Row R0020: Non-available called but not paid in ordinary share capital at group level
 - Row R0060: Non-available subordinated mutual member accounts at group level
 - Row R0080: Non-available surplus at group level
 - Row R0100: Non-available preference shares at group level
 - Row R0120: Non-available share premium account related to preference shares at group level
 - Row R0150: Non-available subordinated liabilities at group level
 - Row R0170: The amount equal to the value of net deferred tax assets not available at the group level
 - Row R0190: Non-available own funds related to other own funds items approved by supervisory authority
 - Row R0210: Non-available minority interests at group level
 - Row R0380: Non-available ancillary own funds at group level
 - Rows R0410 to R0440: Own funds of other financial sectors
 - Row R0680: Group SCR
 - Row R0740: Adjustment for restricted own fund items in respect of matching adjustment portfolios and ring fenced funds
 - Row R0750: Other non-available own funds
- Elements of the Narrative Disclosures subject to audit identified as 'unaudited'.

U K Insurance Limited (Solo Internal Model)

The relevant elements of the SFCR that are not subject to audit comprise:

- The following elements of template S.02.01.02:
 - Row R0550: Technical provisions – non-life (excluding health) – risk margin
 - Row R0590: Technical provisions – health (similar to non-life) – risk margin
 - Row R0640: Technical provisions – health (similar to life) – risk margin
 - Row R0680: Technical provisions – life (excluding health and index-linked and unit-linked) risk margin
 - Row R0720: Technical provisions – Index-linked and unit-linked – risk margin
- The following elements of template S.12.01.02:
 - Row R0100: Technical provisions calculated as a sum of BE and RM – Risk margin
 - Rows R0110 to R0130: Amount of transitional measure on technical provisions
- The following elements of template S.17.01.02:
 - Row R0280: Technical provisions calculated as a sum of BE and RM – Risk margin
 - Rows R0290 to R0310: Amount of transitional measure on technical provisions

F. Other information continued

- The following elements of template S.22.01.21:
 - Column C0030: Impact of transitional measure on technical provisions
 - Row R0010: Technical provisions
 - Row R0090: Solvency Capital Requirement
- The following elements of template S.23.01.01:
 - Row R0580: SCR
 - Row R0740: Adjustment for restricted own fund items in respect of matching adjustment portfolios and ring fenced funds
- The following elements of template S.28.01.01 / S.28.02.01:
 - Row R0310: SCR
- Elements of the Narrative Disclosures subject to audit identified as 'unaudited'.

Churchill Insurance Company Limited (Solo standard formula)

The relevant elements of the SFCR that are not subject to audit comprise:

- The following elements of template S.12.01.02:
 - Rows R0110 to R0130: Amount of transitional measure on technical provisions.
- The following elements of template S.17.01.02:
 - Rows R0290 to R0310: Amount of transitional measure on technical provisions.
- The following elements of template S.22.01.21:
 - Column C0030: Impact of transitional measure on technical provisions.
- Elements of the Narrative Disclosures subject to audit identified as 'unaudited'.

F. Other information continued

F.3 Forward-looking statements disclaimer

This Single SFCR has been prepared for, and only for, the members of the Company as a body, policyholders and supervisory authorities including the PRA, and no other persons. The Company, its Directors, employees, agents or advisers do not accept responsibility to any other person to whom this document is shown or into whose hands it may come, and any such responsibility or liability is expressly disclaimed.

Certain information contained in this document, including any information as to the Group's strategy, plans or future financial or operating performance, constitutes "forward-looking statements". These forward-looking statements may be identified by the use of forward-looking terminology, including the terms "aims", "ambition", "anticipates", "aspire", "believes", "continue", "could", "estimates", "expects", "guidance", "intends", "may", "mission", "outlook", "over the medium term", "plans", "predicts", "projects" "propositions", "seeks", "should", "strategy", "targets" or "will" or, in each case, their negative or other variations or comparable terminology, or by discussions of strategy, plans, objectives, goals, future events or intentions. These forward-looking statements include all matters that are not historical facts. They appear in a number of places throughout this document, and include statements regarding the intentions, beliefs or current expectations of the Directors concerning, among other things: the Group's results of operations, financial condition, prospects, growth, strategies and the industry in which the Group operates. Examples of forward-looking statements include financial targets and guidance which are contained in this document specifically with respect to the return on tangible equity; solvency capital ratio; the Group's combined operating ratio; prior-year reserve releases; cost reduction; reductions in expense and commission ratio; net investment income yield; net realised and unrealised gains; results from the Run-off segment; restructuring costs; and risk appetite range. By their nature, all forward-looking statements involve risk and uncertainties because they relate to events and depend on circumstances that may or may not occur in the future, or are beyond the Group's control.

Forward-looking statements are not guarantees of future performance. The Group's actual results of operations, financial condition and the development of the business sector in which the Group operates may differ materially from those suggested by the forward-looking statements contained in this document, for example directly or indirectly as a result of, but not limited to, UK domestic and global economic business conditions, the outcome of the negotiations relating to the UK's withdrawal from the European Union, market-related risks such as fluctuations in interest rates and exchange rates, the policies and actions of regulatory authorities (including changes related to capital and solvency requirements or the Ogden discount rate), the impact of competition, currency changes, inflation and deflation, the timing impact and other uncertainties of future acquisitions, disposals, joint ventures or combinations within relevant industries, as well as the impact of tax and other legislation and other regulation in the jurisdictions in which the Group and its affiliates operate. In addition, even if the Group's actual results of operations, financial condition and the development of the business sector in which the Group operates are consistent with the forward-looking statements contained in this document, those results or developments may not be indicative of results or developments in subsequent periods.

The forward-looking statements in this document reflect knowledge and information available as of the date of preparation of this document. The Group and the Directors expressly disclaim any obligations or undertaking to update or revise publicly any forward-looking statements, whether as a result of new information, future events or otherwise, unless required to do so by applicable law or regulation. Nothing in this document should be construed as a profit forecast.

Neither the content of Direct Line Group's website nor the content of any other website accessible from hyperlinks on the Group's website is incorporated into, or forms part of, this document.

F. Other information continued

F.4 Glossary

Term	Definition and explanation
Actuarial best estimate ("ABE")	The probability-weighted average of all future claims and cost scenarios. It is calculated using historical data, actuarial methods and judgement. A best estimate of reserves will therefore normally include no margin for optimism or, conversely, caution.
Annual Incentive Plan ("AIP")	This incentivises the performance of executives and employees over a one-year operating cycle. It focuses on the short to medium-term elements of the Group's strategic aims.
Available-for-sale ("AFS") investment	Financial assets that are classified as available-for-sale. Please refer to the accounting policy note 1.12 on page 120 of the Annual Report & Accounts 2017.
Capital	The funds invested in the Group, including funds invested by shareholders and retained profits.
Capital coverage ratio	The ratio of Solvency II own funds to the solvency capital requirement.
Clawback	The ability of the Company to claim repayment of paid amounts for equity settled share-based payments.
Direct Line Insurance Internal Capital Engine ("DIICE")	The Group Insurance Internal Calculation Engine (DIICE) is the calculation kernel in the IECM, where it is DIICE that calculates the SCR.
Financial Conduct Authority ("FCA")	The independent body that regulates firms and financial advisers. It puts the customers' interests and market integrity at the core of financial service providers' activities.
Gross written premium	The total premiums from contracts that began during the period.
International Accounting Standards Board ("IASB")	A not-for-profit public interest organisation that is overseen by a monitoring board of public authorities. It develops IFRS: standards that aim to make worldwide markets transparent, accountable and efficient.
Incurred but not reported ("IBNR")	Funds set aside to meet the cost of claims for accidents that have occurred, but have not yet been reported to the Group. This includes an element of uplift on the value of claims reported. Where the Group has determined that the value currently held in reserves is not sufficient to meet the estimated ultimate costs if the claim is referred to as incurred but not enough reported ("IBNER").
In-force policies	The number of policies on a given date that are active, and against which the Group will pay, following a valid insurance claim.
Insurance liabilities	This comprises insurance claims reserves and claims handling provision, which the Group maintains to meet current and future claims.
Internal Economic Capital Model ("IECM")	The IECM is an internal model as outlined by Article 112 of the Solvency II Directive.
Investment income yield	The income earned from the investment portfolio, recognised through the income statement during the period, divided by the average assets under management ("AUM"). This excludes unrealised and realised gains and losses, impairments, and fair-value adjustments. The average AUM derives from the period's opening and closing balances for the total Group. See page 177 – Alternative performance measures – of the Annual Report & Accounts 2017.
Investment return	The return earned from the investment portfolio, including unrealised and realised gains and losses, impairments, and fair value adjustments.
Investment return yield	The return earned from the investment portfolio, recognised through the income statement during the period divided by the average AUM. This includes unrealised and realised gains and losses, impairments, and fair-value adjustments. The average AUM derives from the period's opening and closing balances. See page 177 – Alternative performance measures – of the Annual Report & Accounts 2017.
Long-Term Incentive Plan ("LTIP")	Awards made as nil-cost options or conditional share awards, which vest to the extent that performance conditions are satisfied after a period of at least three years.
Malus	An arrangement that permits unvested remuneration awards to be forfeited, when the Company considers it appropriate.
Net claims	The cost of claims incurred in the period less any claims costs recovered under reinsurance contracts. It includes claims payments and movements in claims reserves.
Net earned premium	The element of gross earned premium less reinsurance premium ceded for the period where insurance cover has already been provided.
Ogden discount rate	The discount rate set by the Lord Chancellor and used by courts to calculate lump sum awards in bodily injury cases.
Ongoing operations	Ongoing operations comprise Direct Line Group's Ongoing divisions: Motor, Home, Rescue and other personal lines, and Commercial. It excludes run-off and restructuring costs.
Operating profit	The pre-tax profit that the Group's activities generate, including insurance and investment activity, but excluding finance costs.

F. Other information continued

Glossary continued

Term	Definition and explanation
Own Risk and Solvency Assessment ("ORSA")	A solvency requirement. It documents the Group's insurance underwriting entities' risks and associated capital requirements, both now and projected over the business planning period. It is forward looking, reflecting business strategy and risk appetite.
Periodic payment order ("PPO")	These are claims payments as awarded under the Courts Act 2003. PPOs are used to settle large personal injury claims. They generally provide a lump-sum award plus inflation-linked annual payments to claimants who require long-term care.
Prudential Regulation Authority ("PRA")	The PRA is a part of the Bank of England. It is responsible for regulating and supervising insurers and financial institutions in the UK.
Reinsurance	Contractual arrangements where the Group transfers part or all of the accepted insurance risk to another insurer.
Reserves	Funds that have been set aside to meet outstanding insurance claims and IBNR.
Return on Tangible Equity ("RoTE")	Return on Tangible Equity for 2017 is adjusted profit after tax from Ongoing operations excluding one-off costs in relation to the buy-back of subordinated liabilities, divided by the Group's average shareholders' equity, less goodwill and other intangible assets. Profit after tax is adjusted to exclude the Run-off segment and restructuring costs. It is stated after charging tax using the UK standard tax rate of 19.25% (2016: 20.0%). RoTE for comparative periods is adjusted profit after tax from Ongoing operations, divided by the Group's average shareholders' equity, less goodwill and other intangible assets. Profit after tax is adjusted to exclude run-off and restructuring costs. See page 177 – Alternative performance measures of the Annual Report & Accounts 2017.
Run-off	Where the Group no longer underwrites new business, but continues to meet its claims liabilities under existing contracts.
Solvency II	The capital adequacy regime for the European insurance industry, which became effective on 1 January 2016. It establishes revised capital requirements and risk management standards. It comprises three pillars: Pillar I, which sets out capital requirements for an insurer; Pillar II, which focuses on systems of governance; and Pillar III, which deals with disclosure requirements.
Total costs	Total costs comprise operating expenses and claims handling expenses for Ongoing operations.
Total Shareholder Return ("TSR")	Compares share price movement with reinvested dividends as a percentage of the share price at the beginning of the period.
Underwriting result (profit / (loss))	The profit or loss from operational activities, excluding investment return and other operating income. It is calculated as net earned premium less net insurance claims and total expenses.

Section G:

Quantitative Reporting Templates

In this section:

- G.1 Summary of Quantitative Reporting Templates
- G.2 Direct Line Insurance Group plc
- G.3 U K Insurance Limited
- G.4 Churchill Insurance Company Limited

G.1 Summary of Quantitative Reporting Templates

The templates are provided as an appendix to this document. The Company is required to disclose the following templates as set out in the Commission Implementing Regulation (EU) 2015/2452 of 2 December 2015 laying down implementing technical standards with regard to the procedures, formats and templates of the solvency and financial condition report in accordance with Directive 2009/138/EC of the European Parliament and of the Council.

Entity	Template code	Template name
Group	S.02.01.02	Balance sheet
	S.05.01.02	Premiums, claims and expenses by line of business
	S.05.02.01	Premiums, claims and expenses by country
	S.22.01.22	Impact of long-term guarantees and transitional measures
	S.23.01.22	Own funds
	S.25.02.22	Solvency capital requirement – for groups using the standard formula and partial internal model
	S.32.01.22	Undertakings in the scope of the group
UKI	S.02.01.02	Balance sheet
	S.05.01.02	Premiums, claims and expenses by line of business
	S.05.02.01	Premiums, claims and expenses by country
	S.12.01.02	Life and Health SLT technical provisions
	S.17.01.02	Non-life technical provisions
	S.19.01.21	Non-life insurance claims
	S.22.01.21	Impact of long-term guarantees and transitional measures
	S.23.01.01	Own funds
	S.25.03.21	Solvency capital requirement – for undertakings on full internal models
S.28.01.01	Minimum capital requirement – only life or only non-life insurance or reinsurance activity	
CIC	S.02.01.02	Balance sheet
	S.05.01.02	Premiums, claims and expenses by line of business
	S.05.02.01	Premiums, claims and expenses by country
	S.12.01.02	Life and Health SLT technical provisions
	S.17.01.02	Non-life technical provisions
	S.19.01.21	Non-life insurance claims
	S.22.01.21	Impact of long term guarantees and transitional measures
	S.23.01.01	Own funds
	S.25.01.21	Solvency capital requirement – for undertakings on standard formula
S.28.01.01	Minimum capital requirement – only life or only non-life insurance or reinsurance activity	

G.2 Direct Line Insurance Group plc

General information

Undertaking name	Direct Line Insurance Group plc
Undertaking identification code	213800FF2R23AJQOP04
Type of code of undertaking	LEI
Type of undertaking	Insurance holding company as defined in Article 212(1) (f) of Directive 2009/138/EC
Country of authorisation	GB
Language of reporting	EN
Reporting reference date	31 December 2017
Currency used for reporting	GBP
Accounting standards	Group and Company is using IFRS
Method of calculation of the SCR	The Group uses a partial internal model
Matching adjustment	No use of matching adjustment
Volatility adjustment	Volatility adjustment is applied to the following lines of business: Motor vehicle liability insurance General liability insurance Annuities from non-life
Transitional measure on the risk-free interest rate	No use of transitional measure on the risk-free interest rate
Transitional measure on technical provisions	No use of transitional measure on technical provisions

List of reported templates

S.02.01.02	Balance sheet
S.05.01.02	Premiums, claims and expenses by line of business
S.05.02.01	Premiums, claims and expenses by country
S.22.01.22	Impact of long-term guarantees and transitional measures
S.23.01.22	Own funds
S.25.02.22	Solvency capital requirement – for groups using the standard formula and partial internal mod
S.32.01.22	Undertakings in the scope of the group

G.2 Direct Line Insurance Group plc continued

S.02.01.02

Balance sheet (£'000)

		Solvency II value
		C0010
Assets		
R0030	Intangible assets	
R0040	Deferred tax assets	41,945
R0050	Pension benefit surplus	14,401
R0060	Property, plant and equipment held for own use	58,645
R0070	Investments (other than assets held for index-linked and unitlinked contracts)	6,056,939
R0080	Property (other than for own use)	313,504
R0090	Holdings in related undertakings, including participations	
R0100	Equities	
R0110	Equities – listed	
R0120	Equities – unlisted	
R0130	Bonds	4,558,521
R0140	Government bonds	259,198
R0150	Corporate bonds	4,299,323
R0160	Structured notes	
R0170	Collateralised securities	
R0180	Collective investments undertakings	1,100,555
R0190	Derivatives	84,359
R0200	Deposits other than cash equivalents	
R0210	Other investments	
R0220	Assets held for index-linked and unitlinked contracts	
R0230	Loans and mortgages	494,945
R0240	Loans on policies	
R0250	Loans and mortgages to individuals	
R0260	Other loans and mortgages	494,945
R0270	Reinsurance recoverables from:	1,136,151
R0280	Non-life and health similar to non-life	853,579
R0290	Non-life excluding health	853,579
R0300	Health similar to non-life	
R0310	Life and health similar to life, excluding health and index-linked and unitlinked	282,572
R0320	Health similar to life	
R0330	Life excluding health and index-linked and unitlinked	282,572
R0340	Life indexlinked and unitlinked	
R0350	Deposits to cedants	
R0360	Insurance and intermediaries receivables	91,618
R0370	Reinsurance receivables	22,138
R0380	Receivables (trade, not insurance)	129,228
R0390	Own shares (held directly)	37,954
R0400	Amounts due in respect of own fund items or initial fund called up but not yet paid in	
R0410	Cash and cash equivalents	258,010
R0420	Any other assets, not elsewhere shown	21,131
R0500	Total assets	8,363,105

G.2 Direct Line Insurance Group plc continued

S.02.01.02 continued

Balance sheet (£'000)

		Solvency II value
		C0010
Liabilities		
R0510	Technical provisions – non-life	4,530,667
R0520	Technical provisions – non-life (excluding health)	4,513,379
R0530	TP calculated as a whole	
R0540	Best estimate	4,318,408
R0550	Risk margin	194,971
R0560	Technical provisions – health (similar to non-life)	17,288
R0570	TP calculated as a whole	
R0580	Best estimate	15,792
R0590	Risk margin	1,496
R0600	Technical provisions – life (excluding index-linked and unitlinked)	675,127
R0610	Technical provisions – health (similar to life)	
R0620	TP calculated as a whole	
R0630	Best estimate	
R0640	Risk margin	
R0650	Technical provisions – life (excluding health and index-linked and unitlinked)	675,127
R0660	TP calculated as a whole	
R0670	Best estimate	567,969
R0680	Risk margin	107,158
R0690	Technical provisions – index-linked and unitlinked	
R0700	TP calculated as a whole	
R0710	Best estimate	
R0720	Risk margin	
R0740	Contingent liabilities	
R0750	Provisions other than technical provisions	74,179
R0760	Pension benefit obligations	
R0770	Deposits from reinsurers	
R0780	Deferred tax liabilities	
R0790	Derivatives	11,993
R0800	Debts owed to credit institutions	54,136
R0810	Financial liabilities other than debts owed to credit institutions	
R0820	Insurance and intermediaries payables	10,069
R0830	Reinsurance payables	51,557
R0840	Payables (trade, not insurance)	228,067
R0850	Subordinated liabilities	264,818
R0860	Subordinated liabilities not in BOF	
R0870	Subordinated liabilities in BOF	264,818
R0880	Any other liabilities, not elsewhere shown	
R0900	Total liabilities	5,900,613
R1000	Excess of assets over liabilities	2,462,492

G.2 Direct Line Insurance Group plc continued

S.05.01.02

Premiums, claims and expenses by line of business

Non-life (£'000)

		Line of business for: non-life insurance and reinsurance obligations (direct business and accepted proportional reinsurance)				
		Income protection insurance	Motor vehicle liability insurance	Other motor insurance	Fire and other damage to property insurance	General liability insurance
		C0020	C0040	C0050	C0070	C0080
Premiums written						
R0110	Gross – direct business	11,410	1,381,304	391,642	1,000,027	94,197
R0120	Gross – proportional reinsurance accepted					
R0130	Gross – non-proportional reinsurance accepted					
R0140	Reinsurers' share	(1)	146,819		62,288	(2,490)
R0200	Net	11,411	1,234,485	391,642	937,739	96,687
Premiums earned						
R0210	Gross – direct business	11,448	1,320,180	374,274	1,026,271	93,332
R0220	Gross – proportional reinsurance accepted					
R0230	Gross – non-proportional reinsurance accepted					
R0240	Reinsurers' share	(1)	145,250		56,617	899
R0300	Net	11,449	1,174,930	374,274	969,654	92,433
Claims incurred						
R0310	Gross – direct business	3,957	512,282	120,964	443,848	20,847
R0320	Gross – proportional reinsurance accepted					
R0330	Gross – non-proportional reinsurance accepted					
R0340	Reinsurers' share	(1)	(175,996)		(8,016)	(21,495)
R0400	Net	3,958	688,278	120,964	451,864	42,342
Changes in other technical provisions						
R0410	Gross – direct business					
R0420	Gross – proportional reinsurance accepted					
R0430	Gross – non-proportional reinsurance accepted					
R0440	Reinsurers' share					
R0500	Net					
R0550	Expenses incurred	7,805	443,160	135,323	451,254	41,535
R1200	Other expenses					
R1300	Total expenses					

G.2 Direct Line Insurance Group plc continued

S.05.01.02 continued

Premiums, claims and expenses by line of business

Non-life (£'000)

		Line of business for: non-life insurance and reinsurance obligations (direct business and accepted proportional reinsurance)			Total
		Legal expenses insurance C0100	Assistance C0110	Miscellaneous financial loss C0120	
Premiums written					
R0110	Gross – direct business	86,715	312,417	114,416	3,392,128
R0120	Gross – proportional reinsurance accepted				
R0130	Gross – non-proportional reinsurance accepted				
R0140	Reinsurers' share		550	1,239	208,405
R0200	Net	86,715	311,867	113,177	3,183,723
Premiums earned					
R0210	Gross – direct business	87,273	312,437	114,491	3,339,706
R0220	Gross – proportional reinsurance accepted				
R0230	Gross – non-proportional reinsurance accepted				
R0240	Reinsurers' share		550	1,388	204,703
R0300	Net	87,273	311,887	113,103	3,135,003
Claims incurred					
R0310	Gross – direct business	11,956	172,093	67,486	1,353,433
R0320	Gross – proportional reinsurance accepted				
R0330	Gross – non-proportional reinsurance accepted				
R0340	Reinsurers' share	186	587	(2,520)	(207,255)
R0400	Net	11,770	171,506	70,006	1,560,688
Changes in other technical provisions					
R0410	Gross – direct business				
R0420	Gross – proportional reinsurance accepted				
R0430	Gross – non-proportional reinsurance accepted				
R0440	Reinsurers' share				
R0500	Net				
R0550	Expenses incurred	15,428	105,536	32,106	1,232,147
R1200	Other expenses				11,902
R1300	Total expenses				1,244,049

G.2 Direct Line Insurance Group plc continued

S.05.01.02 continued

Premiums, claims and expenses by line of business

Life
(£'000)

		Line of business for: life insurance obligations	Total
		Annuities stemming from non-life insurance contracts and relating to insurance obligations other than health insurance obligations	
		C0260	C0300
Premiums written			
R1410	Gross		
R1420	Reinsurers' share		
R1500	Net		
Premiums earned			
R1510	Gross		
R1520	Reinsurers' share		
R1600	Net		
Claims incurred			
R1610	Gross	42,810	42,810
R1620	Reinsurers' share	24,108	24,108
R1700	Net	18,702	18,702
Changes in other technical provisions			
R1710	Gross		
R1720	Reinsurers' share		
R1800	Net		
R1900	Expenses incurred	2,643	2,643
R2500	Other expenses		
R2600	Total expenses		2,643

G.2 Direct Line Insurance Group plc continued

S.05.02.01

Premiums, claims and expenses by country

Non-life

(£'000)

R0010

C0010	C0020	C0070
Home country	Top 5 countries (by amount of gross premiums written) – non-life obligations	Total top 5 and home country
	IRL	

Premiums written

	C0080	C0090	C0140
R0110 Gross – direct business	3,390,445	1,683	3,392,128
R0120 Gross – proportional reinsurance accepted			
R0130 Gross – non-proportional reinsurance accepted			
R0140 Reinsurers' share	208,405		208,405
R0200 Net	3,182,040	1,683	3,183,723

Premiums earned

R0210 Gross – direct business	3,338,023	1,683	3,339,706
R0220 Gross – proportional reinsurance accepted			
R0230 Gross – non-proportional reinsurance accepted			
R0240 Reinsurers' share	204,703		204,703
R0300 Net	3,133,320	1,683	3,135,003

Claims incurred

R0310 Gross – direct business	1,353,401	32	1,353,433
R0320 Gross – proportional reinsurance accepted			
R0330 Gross – non-proportional reinsurance accepted			
R0340 Reinsurers' share	(207,255)		(207,255)
R0400 Net	1,560,656	32	1,560,688

Changes in other technical provisions

R0410 Gross – direct business			
R0420 Gross – proportional reinsurance accepted			
R0430 Gross – non-proportional reinsurance accepted			
R0440 Reinsurers' share			
R0500 Net			

R0550 Expenses incurred	1,231,587	560	1,232,147
R1200 Other expenses			11,902
R1300 Total expenses			1,244,049

G.2 Direct Line Insurance Group plc continued

S.05.02.01 continued

Premiums, claims and expenses by country

Life

(£'000)

R1400

C0150	C0160	C0210
Home country	Top 5 countries (by amount of gross premiums written) – life obligations	Total top 5 and home country
	IRL	

C0220

C0230

C0280

Premiums written

R1410 Gross
R1420 Reinsurers' share
R1500 Net

Premiums earned

R1510 Gross
R1520 Reinsurers' share
R1600 Net

Claims incurred

R1610 Gross
R1620 Reinsurers' share
R1700 Net

42,810		42,810
24,108		24,108
18,702		18,702

Changes in other technical provisions

R1710 Gross
R1720 Reinsurers' share
R1800 Net

R1900 Expenses incurred
R2500 Other expenses
R2600 Total expenses

2,643		2,643
		2,643

G.2 Direct Line Insurance Group plc continued

S.22.01.22

Impact of long-term guarantees and transitional measures (£'000)

R0010	Technical provisions
R0020	Basic own funds
R0050	Eligible own funds to meet Solvency Capital Requirement
R0090	Solvency Capital Requirement

Amount with long-term guarantee measures and transitionals	Impact of transitional on technical provisions	Impact of transitional on interest rate	Impact of volatility adjustment set to zero	Impact of matching adjustment set to zero
C0010	C0030	C0050	C0070	C0090
5,205,794			54,783	
2,298,676			(21,783)	
2,298,676			(21,783)	
1,392,715			1,899	

G.2 Direct Line Insurance Group plc continued

5.23.01.22

Own funds (£'000)

	Total	Tier 1 – unrestricted	Tier 1 – restricted	Tier 2	Tier 3
	C0010	C0020	C0030	C0040	C0050
Basic own funds before deduction for participations in other financial sector					
R0010 Ordinary share capital (gross of own shares)	150,000	150,000			
R0020 Non-available called but not paid in ordinary share capital at group level					
R0030 Share premium account related to ordinary share capital					
R0040 Initial funds, members' contributions or the equivalent basic own-fund item for mutual and mutual-type Undertakings					
R0050 Subordinated mutual member accounts					
R0060 Non-available subordinated mutual member accounts at group level					
R0070 Surplus funds					
R0080 Non-available surplus funds at group level					
R0090 Preference shares					
R0100 Non-available preference shares at group level					
R0110 Share premium account related to preference shares					
R0120 Non-available share premium account related to preference shares at group level					
R0130 Reconciliation reserve	1,495,371	1,495,371			
R0140 Subordinated liabilities	264,818			264,818	
R0150 Non-available subordinated liabilities at group level					
R0160 An amount equal to the value of net deferred tax assets	41,945				41,945
R0170 The amount equal to the value of net deferred tax assets not available at the group level					
R0180 Other items approved by supervisory authority as basic own funds not specified above	346,542		346,542		
R0190 Non-available own funds related to other own funds items approved by supervisory authority					
R0200 Minority interest (if not reported as part of a specific own fund item)					
R0210 Non-available minority interests at group level					
Own funds from the financial statements that should not be represented by the reconciliation reserve and do not meet the criteria to be classified as Solvency II own funds					
R0220 Own funds from the financial statements that should not be represented by the reconciliation reserve and do not meet the criteria to be classified as Solvency II own funds					
Deductions					
R0230 Deductions for participations in other financial undertakings, including non-regulated undertakings carrying out financial activities					
R0240 whereof deducted according to Article 228 of the Directive 2009/138/EC					
R0250 Deductions for participations where there is non-availability of information (Article 229)					
R0260 Deduction for participations included by using D&A when a combination of methods is used					
R0270 Total of non-available own fund items					
R0280 Total deductions					
R0290 Total basic own funds after deductions	2,298,676	1,645,371	346,542	264,818	41,945

G.2 Direct Line Insurance Group plc continued

5.23.01.22 continued

Own funds

(£'000)

	Total	Tier 1 – unrestricted	Tier 1 –restricted	Tier 2	Tier 3	
	C0010	C0020	C0030	C0040	C0050	
Ancillary own funds						
R0300	Unpaid and uncalled ordinary share capital callable on demand					
R0310	Unpaid and uncalled initial funds, members' contributions or the equivalent basic own fund item for mutual and mutual-type undertakings, callable on demand					
R0320	Unpaid and uncalled preference shares callable on demand					
R0340	Letters of credit and guarantees under Article 96(2) of the Directive 2009/138/EC					
R0350	Letters of credit and guarantees other than under Article 96(2) of the Directive 2009/138/EC					
R0360	Supplementary members calls under first subparagraph of Article 96(3) of the Directive 2009/138/EC					
R0370	Supplementary members calls –other than under first subparagraph of Article 96(3) of the Directive 2009/138/EC					
R0380	Non-available ancillary own funds at group level					
R0390	Other ancillary own funds					
R0400	Total ancillary own funds					
Own funds of other financial sectors						
R0410	Reconciliation reserve					
R0420	Institutions for occupational retirement provision					
R0430	Non regulated entities carrying out financial activities					
R0440	Total own funds of other financial sectors					
Own funds when using the D&A, exclusively or in combination of method 1						
R0450	Own funds aggregated when using the D&A and combination of method					
R0460	Own funds aggregated when using the D&A and combination of method net of IGT					
R0520	Total available own funds to meet the consolidated Group SCR (excluding own funds from other financial sector and from the undertakings included via D&A)	2,298,676	1,645,371	346,542	264,818	41,945
R0530	Total available own funds to meet the minimum consolidated Group SCR	2,256,731	1,645,371	346,542	264,818	
R0560	Total eligible own funds to meet the consolidated Group SCR (excluding own funds from other financial sector and from the undertakings included via D&A)	2,298,676	1,645,371	346,542	264,818	41,945
R0570	Total eligible own funds to meet the minimum consolidated Group SCR	2,112,249	1,645,371	346,542	120,336	

G.2 Direct Line Insurance Group plc continued

5.23.01.22 continued

Own funds

(£'000)

R0610	Minimum consolidated Group SCR
R0650	Ratio of eligible own funds to minimum consolidated Group SCR
R0660	Total eligible own funds to meet the Group SCR (including own funds from other financial sector and from the undertakings included via D&A)
R0680	Group SCR
R0690	Ratio of eligible own funds to Group SCR including other financial sectors and the undertakings Included via D&A

Total	Tier 1 – unrestricted	Tier 1 – restricted	Tier 2	Tier 3
C0010	C0020	C0030	C0040	C0050
601,679				
3.5106				
2,298,676	1,645,371	346,542	264,818	41,945
1,392,715				
1.6505				

Reconciliation reserve

R0700	Excess of assets over liabilities
R0710	Own shares (held directly and indirectly)
R0720	Foreseeable dividends, distributions and charges
R0730	Other basic own fund items
R0740	Adjustment for restricted own fund items in respect of matching adjustment portfolios and ring fenced funds
R0750	Other non-available own funds
R0760	Reconciliation reserve before deduction for participations in other financial sector

C0060
2,462,492
37,954
390,680
538,487
1,495,371

Expected profits

R0770	Expected profits included in future premiums (EPIFP) – life business
R0780	Expected profits included in future premiums (EPIFP) – non-life business
R0790	Total expected profits included in future premiums (EPIFP)

99,114
99,114

Note that the expected profit in future premiums is a Solvency II specific measure of lapse risk and not a measure of overall profitability of the business. Please see C.4 Liquidity risk for details.

G.2 Direct Line Insurance Group plc continued

S.25.02.22

Solvency Capital Requirement – for groups using the standard formula and partial internal model (£'000)

Unique number of component	Components description	Calculation of the Solvency Capital Requirement	Amount modelled	USP	Simplifications
C0010	C0020	C0030	C0070	C0080	C0090
103011	Other interest rate risk – interest rate risk (assets)	344,016	344,016		
103021	Other interest rate risk – interest rate risk (liabilities)	218,779	218,779		
103991	Diversification within other interest rate risk	(366,840)	(366,840)		
104001	Equity risk				
106001	Property risk	70,353	70,353		
107011	Spread risk	543,587	543,587		
107021	Credit risk (asset)	136,988	136,988		
107991	Diversification within spread and credit risk (asset)	(51,766)	(51,766)		
108001	Concentration risk				
109001	Currency risk				
199001	Diversification within market risk	(241,477)	(241,477)		
203001	Other counterparty risk	64,943	64,943		
501001	Premium risk	630,614	630,614		
502001	Reserve risk	619,510	619,510		
503001	Non-life catastrophe risk	548,789	548,789		
599001	Diversification within non-life underwriting risk	(617,425)	(617,425)		
701001	Operational risk	265,781	265,781		
801001	Other risks	42,120	42,120		
803001	Loss-absorbing capacity of deferred tax	(94,882)	(94,882)		
804001	Other adjustments				

G.2 Direct Line Insurance Group plc continued

S.25.02.22 continued

Solvency Capital Requirement – for groups using the standard formula and partial internal model (£'000)

C0100

	Calculation of Solvency Capital Requirement	
R0110	Total undiversified components	2,113,090
R0060	Diversification	(751,618)
R0160	Capital requirement for business operated in accordance with Article 4 of Directive 2003/41/EC	
R0200	Solvency Capital Requirement excluding capital add-on	1,361,472
R0210	Capital add-ons already set	
R0220	Solvency Capital Requirement for undertakings under consolidated method	1,392,715
	Other information on SCR	
R0300	Amount/estimate of the overall loss-absorbing capacity of technical provisions	
R0310	Amount/estimate of the overall loss-absorbing capacity of deferred taxes	(94,882)
R0400	Capital requirement for duration-based equity risk sub-module	
R0410	Total amount of Notional Solvency Capital Requirements for remaining part	
R0420	Total amount of Notional Solvency Capital Requirements for ring fenced funds (other than those related to business operated in accordance with Article 4 of Directive 2003/41/EC (transitional))	
R0430	Total amount of Notional Solvency Capital Requirement for matching adjustment portfolios	
R0440	Diversification effects due to RFF nSCR aggregation for Article 304	
R0470	Minimum consolidated Group Solvency Capital Requirement	601,669
	Information on other entities	
R0500	Capital requirement for other financial sectors (non-insurance capital requirements)	
R0510	Capital requirement for other financial sectors (non-insurance capital requirements) – credit institutions, investment firms and financial institutions, alternative investment funds managers, UCITS management companies	
R0520	Capital requirement for other financial sectors (non-insurance capital requirements) – institutions for occupational retirement provisions	
R0530	Capital requirement for other financial sectors (non-insurance capital requirements) – capital requirement for non-regulated entities carrying out financial activities	
R0540	Capital requirement for non-controlled participation requirements	
R0550	Capital requirement for residual undertakings	31,243
	Overall SCR	
R0560	SCR for undertakings included via D&A	
R0570	Solvency Capital Requirement	1,392,715

G.2 Direct Line Insurance Group plc continued

32.01.22

Undertakings in the scope of the group

Country C0010	Identification code of the undertaking C0020	Type of code of the ID of the undertaking C0030	Legal name of the undertaking C0040	Type of undertaking C0050	Legal form C0060	Category (mutual /non mutual) C0070	Supervisory authority C0080	% capital share C0180	Criteria of influence						Inclusion in the scope of group supervision C0240	Group solvency calculation C0260		
									% used for the establishment of consolidated accounts C0190	% voting rights C0200	Other criteria C0210	Level of influence C0220	Proportional share used for group solvency calculation C0230	Date of decision if Article 214 is applied C0250			Method used and under method 1, treatment of the undertaking	
GB	213800FF2R23AIJQOP04	LEI	Direct Line Insurance Group plc	5	Company limited by shares	2											1	1
GB	549300Z5UV7Z65LTYJ43	LEI	U K Insurance Limited	2	Company limited by shares	2	PRA	100	100	100		1	100	1			1	1
GB	2138007B4PLYNWW611O59	LEI	Churchill Insurance Company Limited	2	Company limited by shares	2	PRA	100	100	100		1	100	1			1	1
GB	2138008ZP4216R8AZA45	LEI	U K Insurance Business Solutions Limited	10	Company limited by shares	2	FCA	100	100	100		1	100	1			1	1
GB	21380093VNH85CCTZM58	LEI	National Breakdown Recovery Club Limited	99	Company limited by shares	2		100	100	100		1	100	1			1	3
GB	213800AEN577VPYUWWS88	LEI	DLG Pension Trustee Limited	99	Company limited by shares	2		100	100	100		1	100	1			1	3
GB	213800C229CRIQN7Q486	LEI	Direct Line Insurance Limited	99	Company limited by shares	2		100	100	100		1	100	1			1	3
GB	213800ECJ98JKW8XPO58	LEI	DL Insurance Services Limited	10	Company limited by shares	2		100	100	100		1	100	1			1	1
GB	213800FUQURSPS5NPZ53	LEI	DLG Legal Services limited	99	Company limited by shares	2		100	100	100		1	100	1			1	3
GB	213800G23ZAHTDQ7JS64	LEI	UKI Life Assurance Services Limited	99	Company limited by shares	2		100	100	100		1	100	1			1	3
GB	213800GGXWCI3AQUP330	LEI	UK Assistance Accident Repair Centres Limited	10	Company limited by shares	2		100	100	100		1	100	1			1	1
GB	213800JGMYQA8ZU3KF17	LEI	Farmweb Limited	99	Company limited by shares	2		100	100	100		1	100	1			1	1
GB	213800L4GCDT4J556J73	LEI	Nationwide Breakdown Recovery Services Limited	99	Company limited by shares	2		100	100	100		1	100	1			1	3
GB	213800LF9K2SZXPFQY79	LEI	UK Assistance Limited	99	Company limited by shares	2		100	100	100		1	100	1			1	3
JE	213800MEX738WOUMSC13	LEI	10-15 Livery Street, Birmingham UK Limited	99	Company limited by shares	2		100	100	100		1	100	1			1	1
GB	213800MFLWGG2N8OVA34	LEI	Green Flag Limited	10	Company limited by shares	2		100	100	100		1	100	1			1	1
GB	213800MN5P5DE45U9W69	LEI	The National Insurance and Guarantee Corporation Limited	99	Company limited by shares	2		100	100	100		1	100	1			1	3
GB	213800MRCD2SJVT8EB37	LEI	Inter Group Insurance Services Limited	10	Company limited by shares	2		100	100	100		1	100	1			1	1
GB	213800R3C7Z1Q73IWN57	LEI	Green Flag Group Limited	99	Company limited by shares	2		100	100	100		1	100	1			1	1
GB	213800RFERZVGSMDGH748	LEI	Finsure Premium Finance Limited	10	Company limited by shares	2		100	100	100		1	100	1			1	1
GB	213800RSEDIUJJHXTF77	LEI	Direct Line Group Limited	99	Company limited by shares	2		100	100	100		1	100	1			1	1
GB	213800S4RFZFA1QH3Y58	LEI	Green Flag Holdings Limited	99	Company limited by shares	2		100	100	100		1	100	1			1	1
IN	213800YY63HNK4VO2G95	LEI	DL Support Services India Private Limited	10	Company limited by shares	2		100	100	100		1	100	1			1	1
GB	213800ZJPTGNL7FP828	LEI	Intergroup Assistance Services Limited	10	Company limited by shares	2		100	100	100		1	100	1			1	1
JE	2138002C5L78GH6J182	LEI	Direct Line Insurance Group Employee Benefit Trust	99	Trust	2			100			1	100	1			1	1
GB	2138007UQ448Q4BRW767	LEI	DLIG 2012 Share Incentive Plan	99	Trust	2			100			1	100	1			1	1

G.3 U K Insurance Limited

General information

Undertaking name	U K Insurance Limited
Undertaking identification code	549300Z5UV7Z65LTYJ43
Type of code of undertaking	LEI
Type of undertaking	Non-life insurance undertakings
Country of authorisation	GB
Language of reporting	EN
Reporting reference date	31 December 2017
Currency used for reporting	GBP
Accounting standards	The undertaking is using IFRS
Method of calculation of the SCR	Full internal model
Matching adjustment	No use of matching adjustment
Volatility adjustment	Volatility adjustment is applied to the following lines of business: Motor vehicle liability insurance General liability insurance Annuities from non-life
Transitional measure on the risk-free interest rate	No use of transitional measure on the risk-free interest rate
Transitional measure on technical provisions	No use of transitional measure on technical provisions

List of reported templates

S.02.01.02	Balance sheet
S.05.01.02	Premiums, claims and expenses by line of business
S.05.02.01	Premiums, claims and expenses by country
S.12.01.02	Life and health SLT technical provisions
S.17.01.02	Non-life technical provisions
S.19.01.21	Non-life insurance claims
S.22.01.21	Impact of long-term guarantees and transitional measures
S.23.01.01	Own funds
S.25.03.21	Solvency capital requirement – for undertakings on full internal models
S.28.01.01	Minimum capital requirement – only life or only non-life insurance or reinsurance activity

G.3 U K Insurance Limited continued

S.02.01.02

Balance sheet (£'000)

		Solvency II Value
		C0010
Assets		
R0030	Intangible assets	
R0040	Deferred tax assets	
R0050	Pension benefit surplus	
R0060	Property, plant and equipment held for own use	
R0070	Investments (other than assets held for index-linked and unitlinked contracts)	5,831,146
R0080	Property (other than for own use)	303,850
R0090	Holdings in related undertakings, including participations	13,349
R0100	Equities	
R0110	Equities – listed	
R0120	Equities – unlisted	
R0130	Bonds	4,553,284
R0140	Government bonds	253,961
R0150	Corporate bonds	4,299,323
R0160	Structured notes	
R0170	Collateralised securities	
R0180	Collective investments undertakings	877,310
R0190	Derivatives	83,353
R0200	Deposits other than cash equivalents	
R0210	Other investments	
R0220	Assets held for index-linked and unitlinked contracts	
R0230	Loans and mortgages	494,945
R0240	Loans on policies	
R0250	Loans and mortgages to individuals	
R0260	Other loans and mortgages	494,945
R0270	Reinsurance recoverables from:	1,120,067
R0280	Non-life and health similar to non-life	854,729
R0290	Non-life excluding health	854,729
R0300	Health similar to non-life	
R0310	Life and health similar to life, excluding health and index-linked and unitlinked	265,338
R0320	Health similar to life	
R0330	Life excluding health and index-linked and unitlinked	265,338
R0340	Life indexlinked and unitlinked	
R0350	Deposits to cedants	
R0360	Insurance and intermediaries receivables	92,117
R0370	Reinsurance receivables	21,648
R0380	Receivables (trade, not insurance)	54,424
R0390	Own shares (held directly)	
R0400	Amounts due in respect of own fund items or initial fund called up but not yet paid in	
R0410	Cash and cash equivalents	245,100
R0420	Any other assets, not elsewhere shown	
R0500	Total assets	7,859,447

G.3 U K Insurance Limited continued

S.02.01.02 continued

Balance sheet (£'000)

		Solvency II value
		C0010
Liabilities		
R0510	Technical provisions – non-life	4,530,268
R0520	Technical provisions – non-life (excluding health)	4,512,980
R0530	TP calculated as a whole	
R0540	Best estimate	4,318,343
R0550	Risk margin	194,637
R0560	Technical provisions – health (similar to non-life)	17,288
R0570	TP calculated as a whole	
R0580	Best estimate	15,792
R0590	Risk margin	1,496
R0600	Technical provisions – life (excluding index-linked and unit-linked)	654,667
R0610	Technical provisions – health (similar to life)	
R0620	TP calculated as a whole	
R0630	Best estimate	
R0640	Risk margin	
R0650	Technical provisions – life (excluding health and index-linked and unit-linked)	654,667
R0660	TP calculated as a whole	
R0670	Best estimate	547,739
R0680	Risk margin	106,928
R0690	Technical provisions – index-linked and unit-linked	
R0700	TP calculated as a whole	
R0710	Best estimate	
R0720	Risk margin	
R0740	Contingent liabilities	
R0750	Provisions other than technical provisions	31,695
R0760	Pension benefit obligations	
R0770	Deposits from reinsurers	
R0780	Deferred tax liabilities	13,229
R0790	Derivatives	11,993
R0800	Debts owed to credit institutions	48,645
R0810	Financial liabilities other than debts owed to credit institutions	134,570
R0820	Insurance and intermediaries payables	12,283
R0830	Reinsurance payables	51,557
R0840	Payables (trade, not insurance)	109,209
R0850	Subordinated liabilities	529,635
R0860	Subordinated liabilities not in BOF	
R0870	Subordinated liabilities in BOF	529,635
R0880	Any other liabilities, not elsewhere shown	
R0900	Total liabilities	6,127,751
R1000	Excess of assets over liabilities	1,731,696

G.3 U K Insurance Limited continued

S.05.01.02

Premiums, claims and expenses by line of business

Non-life

(£'000)

		Line of business for: non-life insurance and reinsurance obligations (direct business and accepted proportional reinsurance)				
		Income protection insurance	Motor vehicle liability insurance	Other motor insurance	Fire and other damage to property insurance	General liability insurance
		C0020	C0040	C0050	C0070	C0080
Premiums written						
R0110	Gross – direct business	11,410	1,381,304	391,642	1,000,027	94,197
R0120	Gross – proportional reinsurance accepted					
R0130	Gross – non-proportional reinsurance accepted					
R0140	Reinsurers' share	(1)	146,819		62,288	(2,490)
R0200	Net	11,411	1,234,485	391,642	937,739	96,687
Premiums earned						
R0210	Gross – direct business	11,448	1,320,180	374,274	1,026,271	93,332
R0220	Gross – proportional reinsurance accepted					
R0230	Gross – non-proportional reinsurance accepted					
R0240	Reinsurers' share	(1)	145,250		56,617	899
R0300	Net	11,449	1,174,930	374,274	969,654	92,433
Claims incurred						
R0310	Gross – direct business	3,957	519,704	203,020	443,848	20,847
R0320	Gross – proportional reinsurance accepted		2,559			
R0330	Gross – non-proportional reinsurance accepted					
R0340	Reinsurers' share	(1)	(167,314)		(8,016)	(21,495)
R0400	Net	3,958	689,577	203,020	451,864	42,342
Changes in other technical provisions						
R0410	Gross – direct business					
R0420	Gross – proportional reinsurance accepted					
R0430	Gross – non-proportional reinsurance accepted					
R0440	Reinsurers' share					
R0500	Net					
R0550	Expenses incurred	7,814	443,520	138,265	454,050	41,572
R1200	Other expenses					
R1300	Total expenses					

G.3 U K Insurance Limited continued

S.05.01.02 continued

Premiums, claims and expenses by line of business

Non-life (£'000)

		Line of business for: non-life insurance and reinsurance obligations (direct business and accepted proportional reinsurance)			Total
		Legal expenses insurance	Assistance	Miscellaneous financial loss	
		C0100	C0110	C0120	C0200
Premiums written					
R0110	Gross – direct business	86,715	312,417	114,416	3,392,128
R0120	Gross – proportional reinsurance accepted				
R0130	Gross – non-proportional reinsurance accepted				
R0140	Reinsurers' share		550	1,239	208,405
R0200	Net	86,715	311,867	113,177	3,183,723
Premiums earned					
R0210	Gross – direct business	87,273	312,437	114,491	3,339,706
R0220	Gross – proportional reinsurance accepted				
R0230	Gross – non-proportional reinsurance accepted				
R0240	Reinsurers' share		550	1,388	204,703
R0300	Net	87,273	311,887	113,103	3,135,003
Claims incurred					
R0310	Gross – direct business	11,956	172,093	67,486	1,442,911
R0320	Gross – proportional reinsurance accepted				2,559
R0330	Gross – non-proportional reinsurance accepted				
R0340	Reinsurers' share	186	587	(2,520)	(198,573)
R0400	Net	11,770	171,506	70,006	1,644,043
Changes in other technical provisions					
R0410	Gross – direct business				
R0420	Gross – proportional reinsurance accepted				
R0430	Gross – non-proportional reinsurance accepted				
R0440	Reinsurers' share				
R0500	Net				
R0550	Expenses incurred	15,450	104,744	32,347	1,237,762
R1200	Other expenses				11,902
R1300	Total expenses				1,249,664

G.3 U K Insurance Limited continued

S.05.02.01

Premiums, claims and expenses by country

Non-life

(£'000)

R0010

Premiums written

R0110	Gross – direct business
R0120	Gross – proportional reinsurance accepted
R0130	Gross – non-proportional reinsurance accepted
R0140	Reinsurers' share
R0200	Net

Premiums earned

R0210	Gross – direct business
R0220	Gross – proportional reinsurance accepted
R0230	Gross – non-proportional reinsurance accepted
R0240	Reinsurers' share
R0300	Net

Claims incurred

R0310	Gross – direct business
R0320	Gross – proportional reinsurance accepted
R0330	Gross – non-proportional reinsurance accepted
R0340	Reinsurers' share
R0400	Net

Changes in other technical provisions

R0410	Gross – direct business
R0420	Gross – proportional reinsurance accepted
R0430	Gross – non-proportional reinsurance accepted
R0440	Reinsurers' share
R0500	Net

Expenses incurred

R1200	Other expenses
R1300	Total expenses

	C0010	C0020	C0070
	Home country	Top 5 countries (by amount of gross premiums written) – non-life obligations	Total top 5 and home country
		IRL	
	C0080	C0090	C0140
	3,390,445	1,683	3,392,128
	208,405		208,405
	3,182,040	1,683	3,183,723
	3,338,023	1,683	3,339,706
	204,703		204,703
	3,133,320	1,683	3,135,003
	1,442,879	32	1,442,911
	2,559		2,559
	(198,573)		(198,573)
	1,644,011	32	1,644,043
	1,237,262	560	1,237,822
			11,902
			1,249,724

G.3 U K Insurance Limited continued

S.12.01.02

Life and Health SLT technical provisions (£'000)

RO010	Technical provisions calculated as a whole
RO020	Total recoverables from reinsurance / SPV and Finite Re after the adjustment for expected losses due to counterparty default associated to TP calculated as a whole
	Technical provisions calculated as a sum of BE and RM
	Best estimate
RO030	Gross best estimate
RO080	Total recoverable from reinsurance / SPV and Finite Re after the adjustment for expected losses due to counterparty default
RO090	Best estimate minus recoverables from reinsurance / SPV and Finite Re – total
RO100	Risk margin
	Amount of the transitional on technical provisions
RO110	Technical provisions calculated as a whole
RO120	Best estimate
RO130	Risk margin
RO200	Technical provisions – total

Annuities stemming from non-life insurance contracts and relating to insurance obligation other than health insurance obligations	Total (life other than health insurance, including unit-linked)
C0090	C0150
547,739	547,739
265,338	265,338
282,401	282,401
106,928	106,928
654,667	654,667

G.3 U K Insurance Limited continued

S.17.01.02

Non-life technical provisions (£'000)

R0010	Technical provisions calculated as a whole
R0050	Total recoverables from reinsurance / SPV and Finite Re after the adjustment for expected losses due to counterparty default associated to TP calculated as a whole
	Technical provisions calculated as a sum of BE and RM
	Best estimate
	Premium provisions
R0060	Gross
R0140	Total recoverable from reinsurance / SPV and Finite Re after the adjustment for expected losses due to counterparty default
R0150	Net best estimate of premium provisions
	Claims provisions
R0160	Gross
R0240	Total recoverable from reinsurance / SPV and Finite Re after the adjustment for expected losses due to counterparty default
R0250	Net best estimate of claims provisions
R0260	Total best estimate – gross
R0270	Total best estimate – net
R0280	Risk margin
	Amount of the transitional on technical provisions
R0290	Technical provisions calculated as a whole
R0300	Best estimate
R0310	Risk margin
	Technical provisions – total
R0320	Technical provisions – total
R0330	Recoverable from reinsurance contract / SPV and Finite Re after the adjustment for expected losses due to counterparty default – total
R0340	Technical provisions minus recoverables from reinsurance / SPV and Finite Re – total

Direct business and accepted proportional reinsurance				
Income protection insurance	Motor vehicle liability insurance	Other motor insurance	Fire and other damage to property insurance	General liability insurance
C0030	C0050	C0060	C0080	C0090
2,215	403,261	167,579	102,680	30,356
	89,294		17,727	1,819
2,215	313,967	167,579	84,953	28,537
13,578	2,761,470	(29,666)	449,508	292,418
	738,205		1,632	5,253
13,578	2,023,265	(29,666)	447,876	287,165
15,792	3,164,731	137,913	552,188	322,774
15,792	2,337,232	137,913	532,829	315,702
1,496	124,865	6,219	42,557	17,012
17,288	3,289,596	144,133	594,745	339,786
	827,499		19,359	7,072
17,288	2,462,097	144,133	575,386	332,715

G.3 U K Insurance Limited continued

S.17.01.02 continued

Non-life technical provisions (£'000)

R0010	Technical provisions calculated as a whole
R0050	Total recoverables from reinsurance / SPV and Finite Re after the adjustment for expected losses due to counterparty default associated to TP calculated as a whole
	Technical provisions calculated as a sum of BE and RM
	Best estimate
	Premium provisions
R0060	Gross
R0140	Total recoverable from reinsurance / SPV and Finite Re after the adjustment for expected losses due to counterparty default
R0150	Net best estimate of premium provisions
	Claims provisions
R0160	Gross
R0240	Total recoverable from reinsurance / SPV and Finite Re after the adjustment for expected losses due to counterparty default
R0250	Net best estimate of claims provisions
R0260	Total best estimate – gross
R0270	Total best estimate – net
R0280	Risk margin
	Amount of the transitional on technical provisions
R0290	Technical provisions calculated as a whole
R0300	Best estimate
R0310	Risk margin
	Technical provisions – total
R0320	Technical provisions – total
R0330	Recoverable from reinsurance contract / SPV and Finite Re after the adjustment for expected losses due to counterparty default – total
R0340	Technical provisions minus recoverables from reinsurance / SPV and Finite Re – total

Direct business and accepted proportional reinsurance			Total non-life obligation
Legal expenses insurance	Assistance	Miscellaneous financial loss	
C0110	C0120	C0130	C0180
(1,188)	20,729	3,008	728,641
		365	109,205
(1,188)	20,729	2,643	619,436
37,410	47,798	32,979	3,605,495
	400	34	745,524
37,410	47,398	32,946	2,859,971
36,222	68,528	35,987	4,334,136
36,222	68,128	35,589	3,479,407
810	1,026	2,148	196,133
37,032	69,554	38,135	4,530,268
	400	399	854,729
37,032	69,153	37,736	3,675,540

G.3 U K Insurance Limited continued

S.19.01.21

Non-life insurance claims (£'000)

Z0010 Accident year / underwriting year

Accident year

Gross claims paid (non-cumulative)

(absolute amount)

Year	Development year											In current year C0170	Sum of years (cumulative) C0180
	0 C0010	1 C0020	2 C0030	3 C0040	4 C0050	5 C0060	6 C0070	7 C0080	8 C0090	9 C0100	10 & + C0110		
R0100	Prior											28,353	28,353
R0160	N-9	1,672,259	838,730	247,064	181,013	137,207	98,138	36,877	19,665	7,883	1,518	1,518	3,240,354
R0170	N-8	1,753,800	888,243	274,126	183,831	167,792	109,687	51,278	21,092	5,521		5,521	3,455,370
R0180	N-7	1,739,292	924,870	245,659	166,882	131,478	80,126	33,609	23,777			23,777	3,345,693
R0190	N-6	1,223,487	492,688	151,157	125,388	91,025	52,862	19,319				19,319	2,155,926
R0200	N-5	1,076,266	508,170	137,775	77,661	63,122	30,240					30,240	1,893,234
R0210	N-4	954,595	458,560	103,549	79,443	57,667						57,667	1,653,814
R0220	N-3	987,142	387,229	104,536	76,229							76,229	1,555,136
R0230	N-2	951,953	439,415	110,803								110,803	1,502,171
R0240	N-1	1,077,689	424,261									424,261	1,501,950
R0250	N	1,126,644										1,126,644	1,126,644
R0260													
	Total											1,904,332	21,458,645

Gross undiscounted best estimate claims provisions

(absolute amount)

Year	Development year											Year end (discounted data) C0360	
	0 C0200	1 C0210	2 C0220	3 C0230	4 C0240	5 C0250	6 C0260	7 C0270	8 C0280	9 C0290	10 & + C0300		
R0100	Prior											111,435	83,224
R0160	N-9								67,211	35,662		33,702	
R0170	N-8							144,383	106,613			95,556	
R0180	N-7						188,171	117,773				107,702	
R0190	N-6					197,912	113,381					102,110	
R0200	N-5				214,705	110,879						104,798	
R0210	N-4			327,333	177,110							170,701	
R0220	N-3		647,359	453,379								410,765	
R0230	N-2		736,605	514,972								478,345	
R0240	N-1	1,405,227	684,613									642,862	
R0250	N	1,447,754										1,375,730	
R0260													
	Total											3,605,495	

G.3 U K Insurance Limited continued

S.22.01.21

Impact of long-term guarantees and transitional measures (£'000)

R0010	Technical provisions
R0020	Basic own funds
R0050	Eligible own funds to meet Solvency Capital Requirement
R0090	Solvency Capital Requirement
R0100	Eligible own funds to meet Minimum Capital Requirement
R0110	Minimum Capital Requirement

Amount with long-term guarantee measures and transitionals	Impact of transitional on technical provisions	Impact of transitional on interest rate	Impact of volatility adjustment set to zero	Impact of matching adjustment set to zero
C0010	C0030	C0050	C0070	C0090
5,184,935			53,901	
1,961,331			(21,647)	
1,961,331			(21,647)	
1,361,472			1,899	
1,551,382			(21,649)	
598,428			1,618	

G.3 U K Insurance Limited continued

S.23.01.01

Own funds (£'000)

Basic own funds before deduction for participations in other financial sector as foreseen in article 68 of Delegated Regulation (EU) 2015/35

RO010	Ordinary share capital (gross of own shares)
RO030	Share premium account related to ordinary share capital
RO040	Initial funds, members' contributions or the equivalent basic own-fund item for mutual and mutual-type undertakings
RO050	Subordinated mutual member accounts
RO070	Surplus funds
RO090	Preference shares
RO110	Share premium account related to preference shares
RO130	Reconciliation reserve
RO140	Subordinated liabilities
RO160	An amount equal to the value of net deferred tax assets
RO180	Other own fund items approved by supervisory authority as basic own funds not specified above

Own funds from the financial statements that should not be represented by the reconciliation reserve and do not meet the criteria to be classified as Solvency II own funds

RO220	Own funds from the financial statements that should not be represented by the reconciliation reserve and do not meet the criteria to be classified as Solvency II own funds
-------	---

Deductions

RO230	Deductions for participations in financial and credit institutions
RO290	Total basic own funds after deductions

Ancillary own funds

RO300	Unpaid and uncalled ordinary share capital callable on demand
RO310	Unpaid and uncalled initial funds, members' contributions or the equivalent basic own fund item for mutual and mutual-type undertakings, callable on demand
RO320	Unpaid and uncalled preference shares callable on demand
RO330	A legally binding commitment to subscribe and pay for subordinated liabilities on demand
RO340	Letters of credit and guarantees under Article 96(2) of the Directive 2009/138/EC
RO350	Letters of credit and guarantees other than under Article 96(2) of the Directive 2009/138/EC
RO360	Supplementary members calls under first subparagraph of Article 96(3) of the Directive 2009/138/EC
RO370	Supplementary members calls — other than under first subparagraph of Article 96(3) of the Directive 2009/138/EC
RO390	Other ancillary own funds
RO400	Total ancillary own funds

Total	Tier 1 – unrestricted	Tier 1 – restricted	Tier 2	Tier 3
C0010	C0020	C0030	C0040	C0050

580,765	580,765			
850,931	850,931			
529,635			529,635	

--

1,961,331	1,431,696		529,635	

G.3 U K Insurance Limited continued

S.23.01.01 continued

Own funds (£'000)

	Total	Tier 1 – unrestricted	Tier 1 – restricted	Tier 2	Tier 3
	C0010	C0020	C0030	C0040	C0050
Available and eligible own funds					
R0500	Total available own funds to meet the SCR	1,961,331	1,431,696	529,635	
R0510	Total available own funds to meet the MCR	1,961,331	1,431,696	529,635	
R0540	Total eligible own funds to meet the SCR	1,961,331	1,431,696	529,635	
R0550	Total eligible own funds to meet the MCR	1,551,382	1,431,696	119,686	
R0580	SCR	1,361,472			
R0600	MCR	598,428			
R0620	Ratio of eligible own funds to SCR	1.4406			
R0640	Ratio of eligible own funds to MCR	2.5924			
Reconciliation reserve					
R0700	Excess of assets over liabilities	1,731,696			
R0710	Own shares (held directly and indirectly)				
R0720	Foreseeable dividends, distributions and charges	300,000			
R0730	Other basic own fund items	580,765			
R0740	Adjustment for restricted own fund items in respect of matching adjustment portfolios and ring fenced funds				
R0760	Reconciliation reserve	850,931			
Expected profits					
R0770	Expected profits included in future premiums (EPIFP) – life business				
R0780	Expected profits included in future premiums (EPIFP) – non-life business	99,114			
R0790	Total expected profits included in future premiums (EPIFP)	99,114			

Note that the expected profit in future premiums is a Solvency II specific measure of lapse risk and not a measure of overall profitability of the business. Please see C.4 Liquidity risk for details.

G.3 U K Insurance Limited continued

S.25.03.21

Solvency Capital Requirement – for undertakings on full internal models (£'000)

Unique number of component	Components description	Calculation of the Solvency Capital Requirement
C0010	C0020	C0030
103011	Other interest rate risk – interest rate risk (assets)	344,016
103021	Other interest rate risk – interest rate risk (liabilities)	218,779
103991	Diversification within other interest rate risk	(366,840)
104001	Equity risk	
106001	Property risk	70,353
107011	Spread risk	543,587
107021	Credit risk (asset)	136,988
107991	Diversification within spread and credit risk (asset)	(51,766)
108001	Concentration risk	
109001	Currency risk	
199001	Diversification within market risk	(241,477)
203001	Other counterparty risk	64,943
501001	Premium risk	630,614
502001	Reserve risk	619,510
503001	Non-life catastrophe risk	548,789
599001	Diversification within non-life underwriting risk	(617,425)
701001	Operational risk	265,781
801001	Other risks	42,120
803001	Lossabsorbing capacity of deferred tax	(94,882)
804001	Other adjustments	

G.3 U K Insurance Limited continued

S.25.03.21 continued

Solvency Capital Requirement – for undertakings on full internal models (£'000)

		C0100
	Calculation of Solvency Capital Requirement	
R0110	Total undiversified components	2,113,090
R0060	Diversification	(751,618)
R0160	Capital requirement for business operated in accordance with Article 4 of Directive 2003/41/EC (transitional)	
R0200	Solvency capital requirement excluding capital add-on	1,361,472
R0210	Capital add-ons already set	
R0220	Solvency Capital Requirement	1,361,472
	Other information on SCR	
R0300	Amount / estimate of the overall loss-absorbing capacity of technical provisions	
R0310	Amount / estimate of the overall loss-absorbing capacity of deferred taxes	(94,882)
R0410	Total amount of Notional Solvency Capital Requirements for remaining part	
R0420	Total amount of Notional Solvency Capital Requirements for ring fenced funds (other than those related to business operated in accordance with Article 4 of Directive 2003/41/EC (transitional))	
R0430	Total amount of Notional Solvency Capital Requirement for matching adjustment portfolios	
R0440	Diversification effects due to RFF nSCR aggregation for Article 304	

G.3 U K Insurance Limited continued

S.28.01.01

Minimum Capital Requirement – only life or only non-life insurance or reinsurance activity (£'000)

Linear formula component for non-life insurance and reinsurance obligations

R0010 MCR_{NL} Result

C0010

592,498

	Net (of reinsurance / SPV) best estimate and TP calculated as a whole	Net (of reinsurance) written premiums in the last 12 months
	C0020	C0030
	15,792	11,411
	2,337,232	1,234,611
	137,913	391,650
	532,829	937,739
	315,702	96,687
	36,222	86,715
	68,128	311,868
	35,589	113,177

R0030	Income protection insurance and proportional reinsurance
R0050	Motor vehicle liability insurance and proportional reinsurance
R0060	Other motor insurance and proportional reinsurance
R0080	Fire and other damage to property insurance and proportional reinsurance
R0090	General liability insurance and proportional reinsurance
R0110	Legal expenses insurance and proportional reinsurance
R0120	Assistance and proportional reinsurance
R0130	Miscellaneous financial loss insurance and proportional reinsurance

G.3 U K Insurance Limited continued

S.28.01.01 continued

Minimum Capital Requirement – only life or only non-life insurance or reinsurance activity (£'000)

Linear formula component for non-life insurance and reinsurance obligations

R0200 MCR: Result

C0040

5,930

Net (of reinsurance / SPV) best estimate and TP calculated as a whole	Net (of reinsurance / SPV) total capital at risk
--	--

C0050

C0060

282,401

R0240 Other life (re)insurance and health (re)insurance obligations

R0250 Total capital at risk for all life (re)insurance obligations

Overall MCR calculation

R0300 Linear MCR

R0310 SCR

R0320 MCR cap

R0330 MCR floor

R0340 Combined MCR

R0350 Absolute floor of the MCR

R0400 Minimum Capital Requirement

C0070

598,428
1,361,472
612,662
340,368
598,428
3,251
598,428

G.4 Churchill Insurance Company Limited

General information

Undertaking name	Churchill Insurance Company Limited
Undertaking identification code	2138007B4PLYNW611O59
Type of code of undertaking	LEI
Type of undertaking	Non-life insurance undertakings
Country of authorisation	GB
Language of reporting	EN
Reporting reference date	31 December 2017
Currency used for reporting	GBP
Accounting standards	The undertaking is using IFRS
Method of calculation of the SCR	Standard formula
Matching adjustment	No use of matching adjustment
Volatility adjustment	Volatility adjustment is applied to the following lines of business: Motor vehicle liability insurance Annuities from non-life
Transitional measure on the risk-free interest rate	No use of transitional measure on the risk-free interest rate
Transitional measure on technical provisions	No use of transitional measure on technical provisions

List of reported templates

S.02.01.02	Balance sheet
S.05.01.02	Premiums, claims and expenses by line of business
S.05.02.01	Premiums, claims and expenses by country
S.12.01.02	Life and health SLT technical provisions
S.17.01.02	Non-life technical provisions
S.19.01.21	Non-life insurance claims
S.22.01.21	Impact of long-term guarantees and transitional measures
S.23.01.01	Own funds
S.25.01.21	Solvency capital requirement – for undertakings on standard formula
S.28.01.01	Minimum capital requirement – only life or only non-life insurance or reinsurance activity

G.4 Churchill Insurance Company Limited continued

S.02.01.02

Balance sheet (£'000)

		Solvency II value
		C0010
Assets		
R0030	Intangible assets	
R0040	Deferred tax assets	
R0050	Pension benefit surplus	
R0060	Property, plant and equipment held for own use	
R0070	Investments (other than assets held for index-linked and unitlinked contracts)	17,745
R0080	Property (other than for own use)	
R0090	Holdings in related undertakings, including participations	
R0100	Equities	
R0110	Equities – listed	
R0120	Equities – unlisted	
R0130	Bonds	
R0140	Government bonds	
R0150	Corporate bonds	
R0160	Structured notes	
R0170	Collateralised securities	
R0180	Collective investments undertakings	17,745
R0190	Derivatives	
R0200	Deposits other than cash equivalents	
R0210	Other investments	
R0220	Assets held for index-linked and unitlinked contracts	
R0230	Loans and mortgages	
R0240	Loans on policies	
R0250	Loans and mortgages to individuals	
R0260	Other loans and mortgages	
R0270	Reinsurance recoverables from:	28,750
R0280	Non-life and health similar to non-life	5,648
R0290	Non-life excluding health	5,648
R0300	Health similar to non-life	
R0310	Life and health similar to life, excluding health and index-linked and unitlinked	23,102
R0320	Health similar to life	
R0330	Life excluding health and index-linked and unitlinked	23,102
R0340	Life indexlinked and unitlinked	
R0350	Deposits to cedants	
R0360	Insurance and intermediaries receivables	
R0370	Reinsurance receivables	491
R0380	Receivables (trade, not insurance)	502
R0390	Own shares (held directly)	
R0400	Amounts due in respect of own fund items or initial fund called up but not yet paid in	
R0410	Cash and cash equivalents	10
R0420	Any other assets, not elsewhere shown	
R0500	Total assets	47,498

G.4 Churchill Insurance Company Limited continued

S.02.01.02 continued

Balance sheet (£'000)

		Solvency II value
		C0010
Liabilities		
R0510	Technical provisions – nonlife	7,196
R0520	Technical provisions – nonlife (excluding health)	7,196
R0530	TP calculated as a whole	
R0540	Best estimate	6,862
R0550	Risk margin	334
R0560	Technical provisions – health (similar to nonlife)	
R0570	TP calculated as a whole	
R0580	Best estimate	
R0590	Risk margin	
R0600	Technical provisions – life (excluding index-linked and unitlinked)	26,329
R0610	Technical provisions – health (similar to life)	
R0620	TP calculated as a whole	
R0630	Best estimate	
R0640	Risk margin	
R0650	Technical provisions – life (excluding health and index-linked and unitlinked)	26,329
R0660	TP calculated as a whole	
R0670	Best estimate	26,099
R0680	Risk margin	230
R0690	Technical provisions – index-linked and unitlinked	
R0700	TP calculated as a whole	
R0710	Best estimate	
R0720	Risk margin	
R0740	Contingent liabilities	
R0750	Provisions other than technical provisions	
R0760	Pension benefit obligations	
R0770	Deposits from reinsurers	
R0780	Deferred tax liabilities	118
R0790	Derivatives	
R0800	Debts owed to credit institutions	
R0810	Financial liabilities other than debts owed to credit institutions	197
R0820	Insurance and intermediaries payables	
R0830	Reinsurance payables	
R0840	Payables (trade, not insurance)	310
R0850	Subordinated liabilities	
R0860	Subordinated liabilities not in BOF	
R0870	Subordinated liabilities in BOF	
R0880	Any other liabilities, not elsewhere shown	
R0900	Total liabilities	34,150
R1000	Excess of assets over liabilities	13,348

G.4 Churchill Insurance Company Limited continued

S.05.01.02

Premiums, claims and expenses by line of business

Non-life (£'000)

		Line of business for: non-life insurance and reinsurance obligations (direct business and accepted proportional reinsurance)	Total
		C0040	C0200
Premiums written			
R0110	Gross – direct business		
R0120	Gross – proportional reinsurance accepted		
R0130	Gross – non-proportional reinsurance accepted		
R0140	Reinsurers' share		
R0200	Net		
Premiums earned			
R0210	Gross – direct business		
R0220	Gross – proportional reinsurance accepted		
R0230	Gross – non-proportional reinsurance accepted		
R0240	Reinsurers' share		
R0300	Net		
Claims incurred			
R0310	Gross – direct business	(7,372)	(7,372)
R0320	Gross – proportional reinsurance accepted		
R0330	Gross – non-proportional reinsurance accepted		
R0340	Reinsurers' share	(5,923)	(5,923)
R0400	Net	(1,449)	(1,449)
Changes in other technical provisions			
R0410	Gross – direct business		
R0420	Gross – proportional reinsurance accepted		
R0430	Gross – non-proportional reinsurance accepted		
R0440	Reinsurers' share		
R0500	Net		
R0550	Expenses incurred	(77)	(77)
R1200	Other expenses		
R1300	Total expenses		(77)

G.4 Churchill Insurance Company Limited continued

S.05.01.02 continued

Premiums, claims and expenses by line of business

Life
(£'000)

		Line of business for: life insurance obligations	Total
		C0260	C0300
Premiums written			
R1410	Gross		
R1420	Reinsurers' share		
R1500	Net		
Premiums earned			
R1510	Gross		
R1520	Reinsurers' share		
R1600	Net		
Claims incurred			
R1610	Gross	1,120	1,120
R1620	Reinsurers' share	982	982
R1700	Net	138	138
Changes in other technical provisions			
R1710	Gross		
R1720	Reinsurers' share		
R1800	Net		
R1900	Expenses incurred	(163)	(163)
R2500	Other expenses		
R2600	Total expenses		(163)

G.4 Churchill Insurance Company Limited continued

S.05.02.01

Premiums, claims and expenses by country

Non-life

(£'000)

R0010

C0010	C0070
Home country	Total top 5 and home country

Premiums written

R0110	Gross – direct business
R0120	Gross – proportional reinsurance accepted
R0130	Gross – non-proportional reinsurance accepted
R0140	Reinsurers' share
R0200	Net

C0080	C0140

Premiums earned

R0210	Gross – direct business
R0220	Gross – proportional reinsurance accepted
R0230	Gross – non-proportional reinsurance accepted
R0240	Reinsurers' share
R0300	Net

Claims incurred

R0310	Gross – direct business
R0320	Gross – proportional reinsurance accepted
R0330	Gross – non-proportional reinsurance accepted
R0340	Reinsurers' share
R0400	Net

(7,372)	(7,372)
(5,923)	(5,923)
(1,449)	(1,449)

Changes in other technical provisions

R0410	Gross – direct business
R0420	Gross – proportional reinsurance accepted
R0430	Gross – non-proportional reinsurance accepted
R0440	Reinsurers' share
R0500	Net

Expenses incurred

R0550	Expenses incurred
R1200	Other expenses
R1300	Total expenses

(77)	(77)
	(77)

G.4 Churchill Insurance Company Limited continued

S.12.01.02

Life and Health SLT technical provisions (£'000)

RO010	Technical provisions calculated as a whole
RO020	Total recoverables from reinsurance / SPV and Finite Re after the adjustment for expected losses due to counterparty default associated to TP calculated as a whole
	Technical provisions calculated as a sum of BE and RM
	Best estimate
RO030	Gross best estimate
RO080	Total recoverable from reinsurance / SPV and Finite Re after the adjustment for expected losses due to counterparty default
RO090	Best estimate minus recoverables from reinsurance / SPV and Finite Re – total
RO100	Risk margin
	Amount of the transitional on technical provisions
RO110	Technical provisions calculated as a whole
RO120	Best estimate
RO130	Risk margin
RO200	Technical provisions – total

Annuities stemming from non-life insurance contracts and relating to insurance obligation other than health insurance obligations	Total (life other than health insurance, including unit-linked)
C0090	C0150
26,099	26,099
23,102	23,102
2,997	2,997
230	230
26,329	26,329

G.4 Churchill Insurance Company Limited continued

S.19.01.21

Non-life insurance claims (£'000)

Z0010 Accident year / underwriting year

Accident year

Gross claims paid (non-cumulative)
(absolute amount)

	Year	Development year										In current year C0170	Sum of years (cumulative) C0180	
		0 C0010	1 C0020	2 C0030	3 C0040	4 C0050	5 C0060	6 C0070	7 C0080	8 C0090	9 C0100			10 & + C0110
R0100	Prior											958	958	958
R0160	N-9													
R0170	N-8													
R0180	N-7													
R0190	N-6													
R0200	N-5													
R0210	N-4													
R0220	N-3													
R0230	N-2													
R0240	N-1													
R0250	N													
R0260														
	Total											958	958	958

Gross undiscounted best estimate claims provisions
(absolute amount)

	Year	Development year										Year end (discounted data) C0360	
		0 C0200	1 C0210	2 C0220	3 C0230	4 C0240	5 C0250	6 C0260	7 C0270	8 C0280	9 C0290		10 & + C0300
R0100	Prior											7,934	6,862
R0160	N-9												
R0170	N-8												
R0180	N-7												
R0190	N-6												
R0200	N-5												
R0210	N-4												
R0220	N-3												
R0230	N-2												
R0240	N-1												
R0250	N												
R0260													
	Total											6,862	6,862

G.4 Churchill Insurance Company Limited continued

S.22.01.21

Impact of long-term guarantees and transitional measures (£'000)

R0010	Technical provisions
R0020	Basic own funds
R0050	Eligible own funds to meet Solvency Capital Requirement
R0090	Solvency Capital Requirement
R0100	Eligible own funds to meet Minimum Capital Requirement
R0110	Minimum Capital Requirement

Amount with long-term guarantee measures and transitionals	Impact of transitional on technical provisions	Impact of transitional on interest rate	Impact of volatility adjustment set to zero	Impact of matching adjustment set to zero
C0010	C0030	C0050	C0070	C0090
33,525			1,387	
13,348			(136)	
13,348			(136)	
1,731			12	
13,348			(136)	
3,251				

G.4 Churchill Insurance Company Limited continued

S.23.01.01 continued

Own funds (£'000)

Available and eligible own funds	
R0500	Total available own funds to meet the SCR
R0510	Total available own funds to meet the MCR
R0540	Total eligible own funds to meet the SCR
R0550	Total eligible own funds to meet the MCR
R0580	SCR
R0600	MCR
R0620	Ratio of eligible own funds to SCR
R0640	Ratio of eligible own funds to MCR
Reconciliation reserve	
R0700	Excess of assets over liabilities
R0710	Own shares (held directly and indirectly)
R0720	Foreseeable dividends, distributions and charges
R0730	Other basic own fund items
R0740	Adjustment for restricted own fund items in respect of matching adjustment portfolios and ring fenced funds
R0760	Reconciliation reserve
Expected profits	
R0770	Expected profits included in future premiums (EPIFP) —life business
R0780	Expected profits included in future premiums (EPIFP) —non-life business
R0790	Total expected profits included in future premiums (EPIFP)

Total	Tier 1 – unrestricted	Tier 1 – restricted	Tier 2	Tier 3
C0010	C0020	C0030	C0040	C0050
13,348	13,348			
13,348	13,348			
13,348	13,348			
13,348	13,348			
1,731				
3,251				
7.711				
4.1065				
C0060				
13,348				
13,348				

G.4 Churchill Insurance Company Limited continued

S.25.01.21

Solvency Capital Requirement – for undertakings on standard formula (£'000)

R0010	Market risk
R0020	Counterparty default risk
R0030	Life underwriting risk
R0040	Health underwriting risk
R0050	Non-life underwriting risk
R0060	Diversification
R0070	Intangible asset risk
R0100	Basic Solvency Capital Requirement
	Calculation of Solvency Capital Requirement
R0130	Operational risk
R0140	Loss-absorbing capacity of technical provisions
R0150	Loss-absorbing capacity of deferred taxes
R0160	Capital requirement for business operated in accordance with Article 4 of Directive 2003/41/EC
R0200	Solvency capital requirement excluding capital add-on
R0210	Capital add-on already set
R0220	Solvency Capital Requirement
	Other information on SCR
R0400	Capital requirement for duration-based equity risk sub-module
R0410	Total amount of Notional Solvency Capital Requirement for remaining part
R0420	Total amount of Notional Solvency Capital Requirements for ring fenced funds
R0430	Total amount of Notional Solvency Capital Requirements for matching adjustment portfolios
R0440	Diversification effects due to RFF nSCR aggregation for Article 304

Gross solvency capital requirement	USP	Simplifications
C0110	C0090	C0100
573		
895		
118	None	
328	None	
(506)		
1,408		
		C0100
		323
		1,731
		1,731

G.4 Churchill Insurance Company Limited continued

S.28.01.01

Minimum Capital Requirement – only life or only non-life insurance or reinsurance activity (£'000)

Linear formula component for non-life insurance and reinsurance obligations

R0010	MCR _{NL} Result	C0010	103		
				Net (of reinsurance / SPV) best estimate and TP calculated as a whole	Net (of reinsurance) written premiums in the last 12 months
				C0020	C0030
R0050	Motor vehicle liability insurance and proportional reinsurance			1,214	
R0200	MCR _L Result	C0040	63		
				Net (of reinsurance / SPV) best estimate and TP calculated as a whole	Net (of reinsurance / SPV) total capital at risk
				C0050	C0060
R0240	Other life (re)insurance and health (re)insurance obligations			2,997	
R0250	Total capital at risk for all life (re)insurance obligations				
	Overall MCR calculation				
R0300	Linear MCR	C0070	166		
R0310	SCR		1,731		
R0320	MCR cap		779		
R0330	MCR floor		433		
R0340	Combined MCR		433		
R0350	Absolute floor of the MCR		3,251		
R0400	Minimum Capital Requirement		3,251		